

Please write clearly in block capitals.

Centre number

--	--	--	--	--

Candidate number

--	--	--	--

Surname

---

Forename(s)

---

Candidate signature

---

I declare this is my own work.

# GCSE PHYSICS

# F

Foundation Tier Paper 1

Wednesday 20 May 2020 Afternoon Time allowed: 1 hour 45 minutes

## Materials

For this paper you must have:

- a ruler
- a scientific calculator
- the Physics Equations Sheet (enclosed).

## Instructions

- Use black ink or black ball-point pen. Pencil should only be used for drawing.
- Fill in the boxes at the top of this page.
- Answer **all** questions in the spaces provided.
- Do not write outside the box around each page or on blank pages.
- If you need extra space for your answer(s), use the lined pages at the end of this book. Write the question number against your answer(s).
- Do all rough work in this book. Cross through any work you do not want to be marked.
- In all calculations, show clearly how you work out your answer.

## Information

- The maximum mark for this paper is 100.
- The marks for questions are shown in brackets.
- You are expected to use a calculator where appropriate.
- You are reminded of the need for good English and clear presentation in your answers.

For Examiner's Use	
Question	Mark
1	
2	
3	
4	
5	
6	
7	
8	
9	
10	
<b>TOTAL</b>	



Answer **all** questions in the spaces provided.

Do not write  
outside the  
box

0 1

**Figure 1** shows how the National Grid connects power stations to consumers.

**Figure 1**

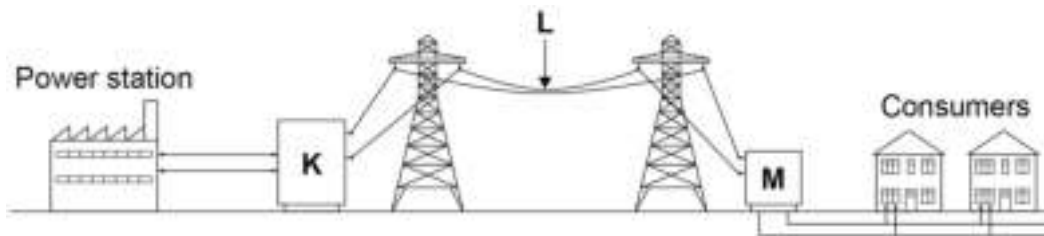

0 1 . 1

Name the parts of the National Grid labelled K, L and M.

**[3 marks]**

K = \_\_\_\_\_

L = \_\_\_\_\_

M = \_\_\_\_\_

**Figure 2** shows how the percentage of electricity generated by gas-fired power stations changed in the UK over 5 years.

**Figure 2**

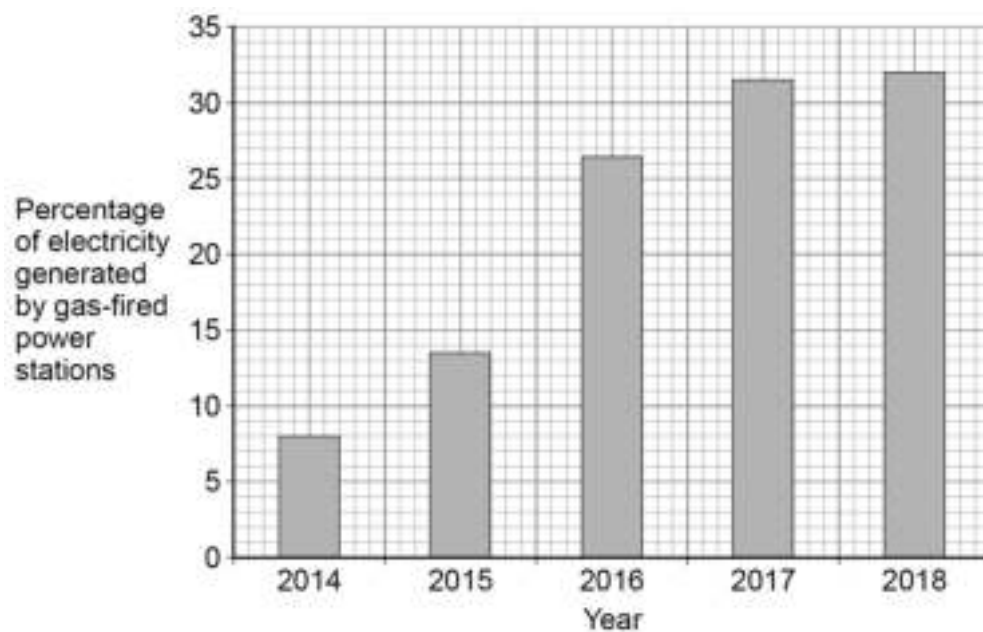

0 1 . 2

Calculate how many times greater the percentage of electricity generated by gas-fired power stations was in 2018 than in 2014.

[2 marks]

---



---



---

Number of times greater = \_\_\_\_\_

0 1 . 3

Explain **one** environmental effect of generating electricity using a gas-fired power station.

[2 marks]

---



---



---



---

0 1 . 4

The UK government wants more electricity to be generated using renewable energy resources.

What is a renewable energy resource?

[1 mark]

Tick (✓) **one** box.

An energy resource that can be burned

An energy resource that can be recycled

An energy resource that can be replenished quickly

An energy resource that can be reused

**Question 1 continues on the next page**

**Turn over ►**



**0 1 . 5** An offshore wind farm is a group of wind turbines that are placed out at sea.

**Figure 3** shows the power output of an offshore wind farm compared with a wind farm on land for a 24-hour period.

**Figure 3**

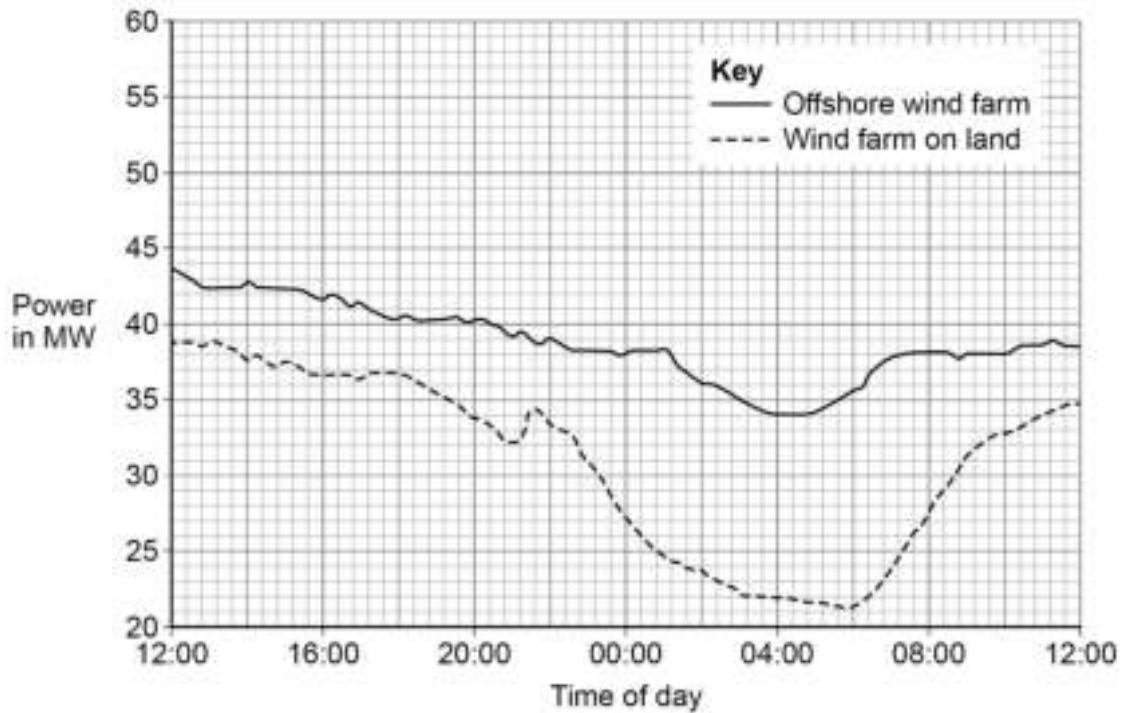

Give **two** advantages of the offshore wind farm compared with the wind farm on land.

Use information from **Figure 3**.

**[2 marks]**

1 \_\_\_\_\_

\_\_\_\_\_

2 \_\_\_\_\_

\_\_\_\_\_

**10**



**Turn over for the next question**

*Do not write  
outside the  
box*

**DO NOT WRITE ON THIS PAGE  
ANSWER IN THE SPACES PROVIDED**

**Turn over ►**



0 2

Figure 4 shows a theme park ride called AquaShute.

Figure 4

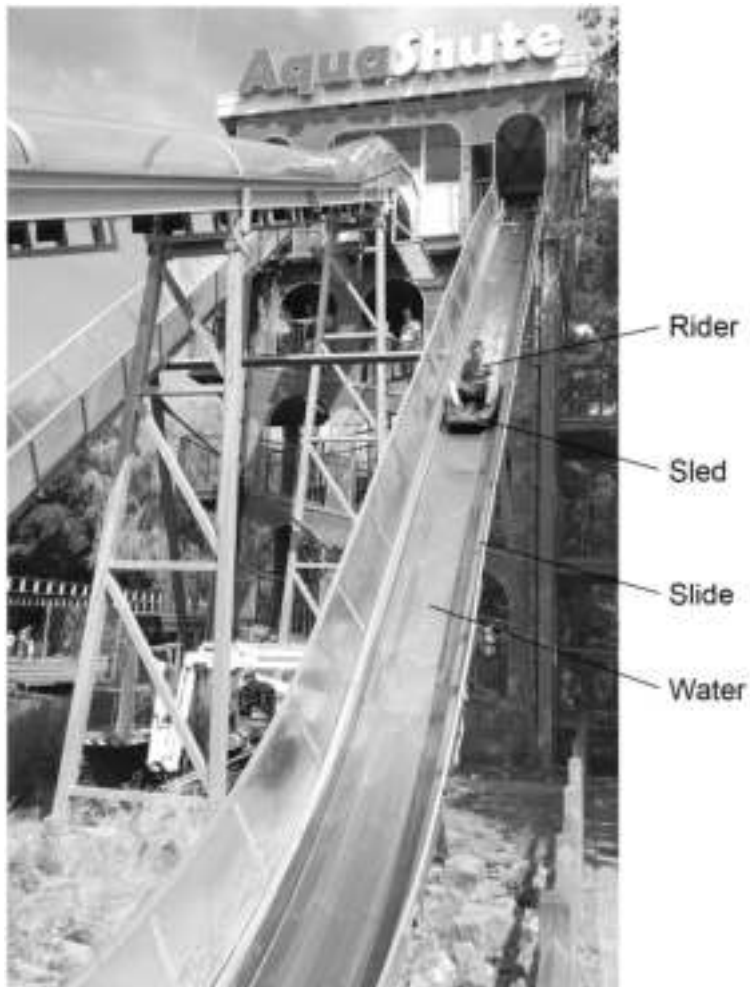

0 2 . 1

Riders of the AquaShute sit on a sled and move down a slide.

There is a layer of water between the sled and the slide.

How does the layer of water affect the friction between the sled and the slide?

[1 mark]

Tick (✓) **one** box.

The friction is decreased.

The friction is increased.

The friction is not affected.



**0 2 . 2** The mass of one rider is 62.5 kg.

The height of the slide is 16.0 m.

gravitational field strength = 9.8 N/kg

Calculate the gravitational potential energy of the rider at the top of the slide.

Use the equation:

$$\text{gravitational potential energy} = \text{mass} \times \text{gravitational field strength} \times \text{height}$$

**[2 marks]**

---



---



---



---

Gravitational potential energy = \_\_\_\_\_ J

**0 2 . 3** At the bottom of the slide the speed of the rider is 12 m/s.

The mass of the rider is 62.5 kg.

Calculate the kinetic energy of the rider at the bottom of the slide.

Use the equation:

$$\text{kinetic energy} = 0.5 \times \text{mass} \times (\text{speed})^2$$

**[2 marks]**

---



---



---



---

Kinetic energy = \_\_\_\_\_ J

**Question 2 continues on the next page**

**Turn over ►**



0 2 . 4

When a rider reaches the bottom of the slide, the sled decelerates and stops.

Give **two** factors that will affect how far the sled will move before it stops.

**[2 marks]**

1 \_\_\_\_\_

\_\_\_\_\_

2 \_\_\_\_\_

\_\_\_\_\_

*Do not write  
outside the  
box*

7





**Turn over for the next question**

*Do not write  
outside the  
box*

**DO NOT WRITE ON THIS PAGE  
ANSWER IN THE SPACES PROVIDED**

**Turn over ►**



0 3

Figure 5 shows part of a lighting circuit in a house.

Figure 5

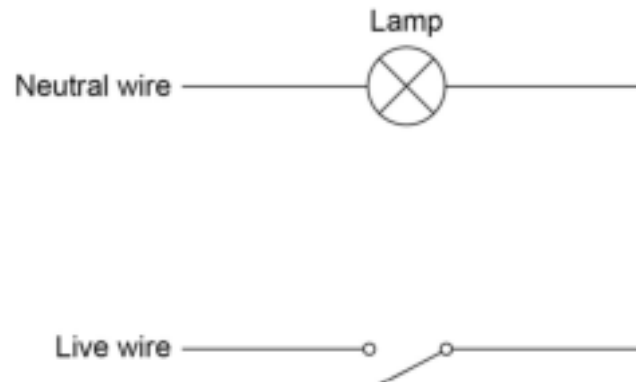

0 3 . 1

What is the frequency of the ac mains electricity supply in the UK?

[1 mark]

Tick (✓) **one** box.

20 Hz       50 Hz       60 Hz       100 Hz

0 3 . 2

The mains electricity supply has an alternating potential difference.

Which diagram shows an alternating potential difference?

[1 mark]

Tick (✓) **one** box.

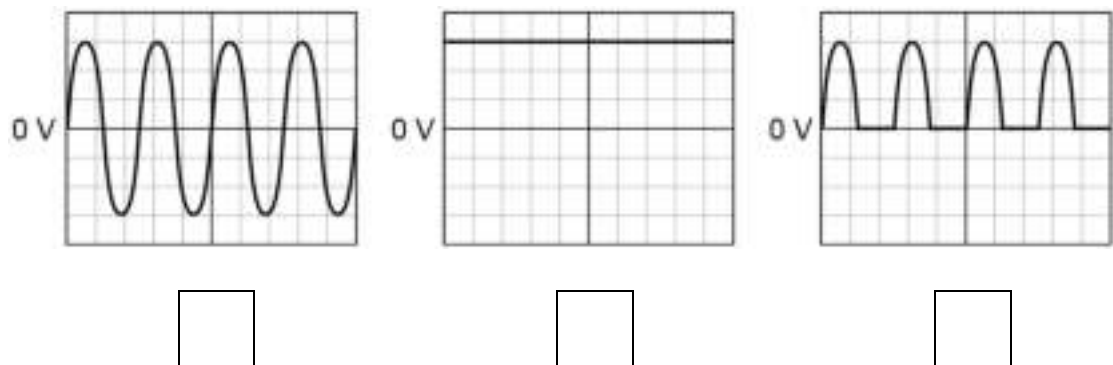

0 3 . 3

The potential difference across the lamp is 230 V.

The current in the lamp is 0.020 A.

Calculate the power output of the lamp.

Use the equation:

$$\text{power} = \text{potential difference} \times \text{current}$$

[2 marks]

---



---



---

$$\text{Power} = \text{_____} \text{ W}$$

0 3 . 4

The potential difference across the lamp is 230 V.

Calculate the energy transferred by the lamp when 180 C of charge flows through the lamp.

Use the equation:

$$\text{energy transferred} = \text{charge flow} \times \text{potential difference}$$

[2 marks]

---



---



---

$$\text{Energy transferred} = \text{_____} \text{ J}$$

0 3 . 5

An electrician needs to replace the light switch in **Figure 5**.

Describe the possible hazard and the risk to the electrician of changing the light switch.

[2 marks]

Hazard \_\_\_\_\_

---

Risk \_\_\_\_\_

---

8



0 4

A student investigated how the total resistance of identical resistors connected in series varied with the number of resistors.

The student used an ohmmeter to measure the total resistance of the resistors.

**Figure 6** shows the student's circuit with 3 resistors.

**Figure 6**



The student repeated each reading of resistance three times.

**Table 1** shows the student's results for 3 resistors in series.

**Table 1**

Number of resistors	Total resistance in $\Omega$			
	Reading 1	Reading 2	Reading 3	Mean
3	35.9	36.0	36.1	36.0

0 4

. 1

Calculate the mean resistance of 1 resistor.

**[2 marks]**

---



---



---

Resistance = \_\_\_\_\_  $\Omega$

0 4

. 2

What was the resolution of the ohmmeter the student used?

Tick (✓) **one** box.

**[1 mark]**

0.1  $\Omega$        0.2  $\Omega$        1.1  $\Omega$        36.0  $\Omega$



**0 4 . 3** How do the results show that the student's measurements were precise?

**[1 mark]**

Tick (✓) **one** box.

The measurements are accurate.

The measurements are grouped closely together.

The measurements are reproducible.

**Question 4 continues on the next page**

**Turn over ►**



Figure 7 shows the results.

Figure 7

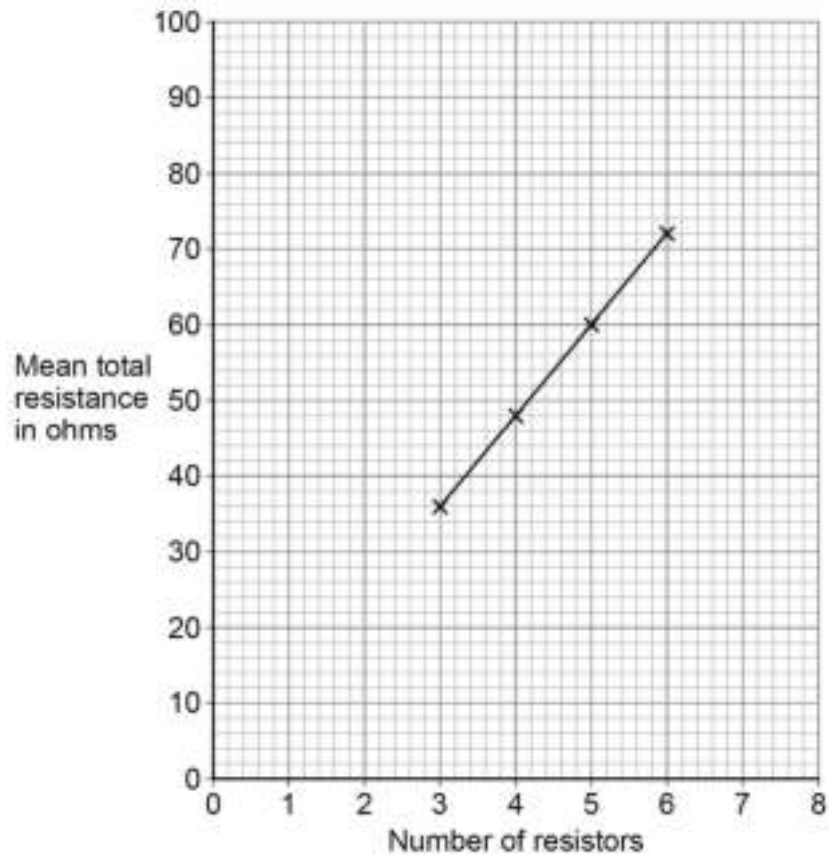

0 4 . 4

How do the results show that the total resistance is directly proportional to the number of resistors?

[1 mark]

Tick (✓) **one** box.

The results give a line with a positive gradient.

The results give a straight line that would go through the origin.

The results show a linear relationship.



**0 4 . 5** Predict the mean total resistance of 7 resistors.

Use **Figure 7**.

**[1 mark]**

Mean total resistance of 7 resistors = \_\_\_\_\_  $\Omega$

**0 4 . 6** Some resistors are connected in series with a battery.

When more resistors are added in series, the total resistance increases.

Complete the sentences.

Choose answers from the box.

Each answer may be used once, more than once or not at all.

**[2 marks]**

**decreases**

**increases**

**remains the same**

When the number of resistors increases, the potential difference across each resistor \_\_\_\_\_.

When the number of resistors increases, the current in the circuit \_\_\_\_\_.

8

**Turn over for the next question**

**Turn over ►**



**0 5**

Radioactive waste from nuclear power stations is a man-made source of background radiation.

**0 5 . 1**

Which of the following is also a man-made source of background radiation?

**[1 mark]**

Tick (✓) **one** box.

cosmic rays

radiotherapy

rocks

stars

**0 5 . 2**

Nuclear power stations use the process of nuclear fission.

Complete the sentences to describe the process of nuclear fission.

Choose answers from the box.

**[3 marks]****a neutron****a proton****an electron****cosmic rays****energy****gamma rays****x-rays**

An unstable nucleus absorbs \_\_\_\_\_ and splits into two parts.

Two or three neutrons are released, as well as \_\_\_\_\_

and \_\_\_\_\_ .





**0 5 . 3**

Plutonium-239 is one type of radioactive waste from nuclear power stations.

The following nuclear equation represents the decay of plutonium-239 (Pu-239).

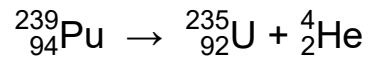

How does the nuclear equation show that alpha radiation is emitted when plutonium-239 decays?

**[1 mark]**

Tick (✓) **one** box.

An alpha particle contains 92 protons.

An alpha particle has a mass number of 235.

An alpha particle is the same as a helium nucleus.

**Question 5 continues on the next page**

**Turn over ►**

Figure 8 shows how the activity of a sample of plutonium-239 varies with time.

Do not write  
outside the  
box

Figure 8

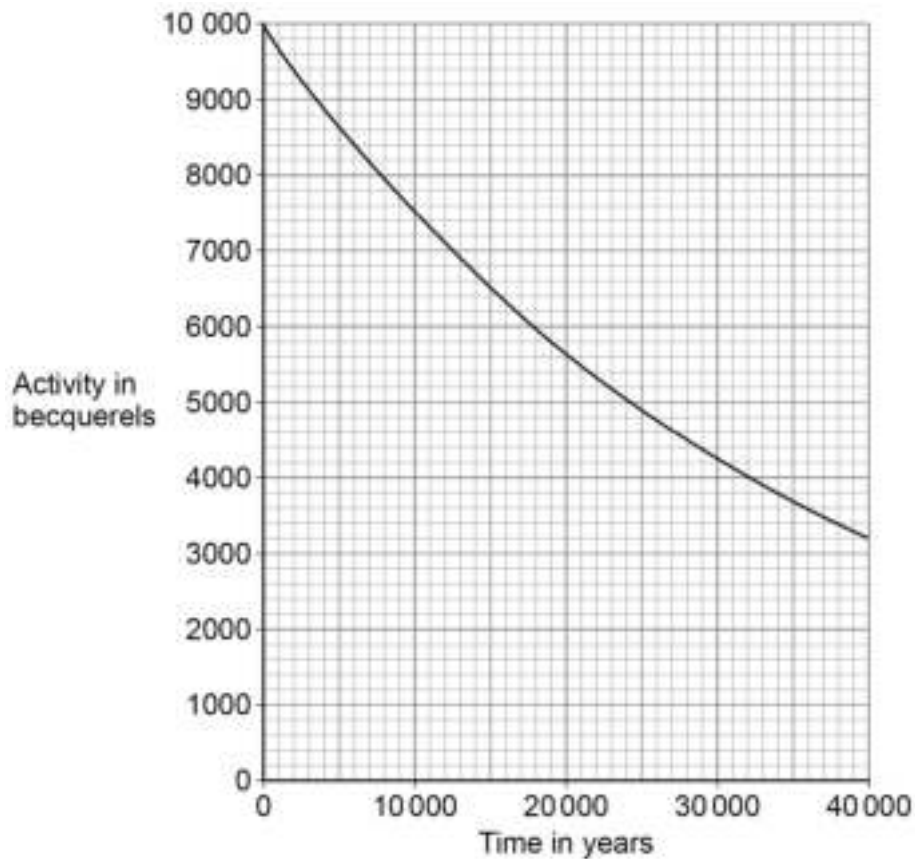

0 5 . 4

How much time will it take for the activity of the sample of plutonium-239 to fall to half of its initial activity?

[1 mark]

Time = \_\_\_\_\_ years

0 5 . 5

What is the half-life of plutonium-239?

[1 mark]

Half-life = \_\_\_\_\_ years



0 5 . 6

The radioactive waste from a nuclear power station is buried underground.

People are warned to stay away from places where radioactive waste is buried.

Suggest **one** risk of going near the place where radioactive waste is buried.

**[1 mark]**

---

---

---

---

---

**8**

**Turn over for the next question**

**Turn over ►**

0 6

A student used the equipment in **Figure 9** to investigate how the pressure of a gas varies with the volume of the gas.

Do not write  
outside the  
box

**Figure 9**

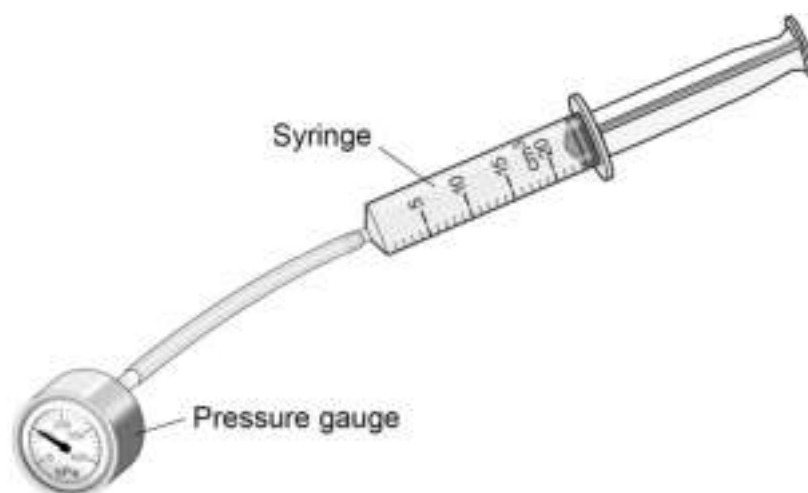

The syringe is filled with air.

**Table 2** shows the results.

**Table 2**

Volume in cm <sup>3</sup>	Pressure in kPa
24	100
20	120
12	200
10	240



**0 6 . 1**

Describe how the student could use the equipment in **Figure 9** to obtain the data shown in **Table 2**.

**[4 marks]**

---

---

---

---

---

---

---

---

---

---

**0 6 . 2**

Describe what happens to the pressure of the air when the volume of the air is halved.

**[2 marks]**

---

---

---

---

**Question 6 continues on the next page**

**Turn over ►**

0 6 . 3

The temperature of the air in the syringe remained constant during the student's investigation.

Which **two** properties of the air particles would change if the temperature increased?

**[2 marks]**

Tick (✓) **two** boxes.

kinetic energy

mass

shape

speed

volume

8



**Turn over for the next question**

*Do not write  
outside the  
box*

**DO NOT WRITE ON THIS PAGE  
ANSWER IN THE SPACES PROVIDED**

**Turn over ►**



0 7

A student heated water in an electric kettle.

0 7 . 1

Water has a high specific heat capacity.

Complete the sentence.

Choose answers from the box.

**[2 marks]**

$^{\circ}\text{C}$	J	kg	s	W
--------------------	---	----	---	---

The specific heat capacity of a substance is the energy needed to raise the temperature of 1 \_\_\_\_\_ of the substance by 1 \_\_\_\_\_.

0 7 . 2

The kettle circuit contains a thermistor which is used to switch the kettle off when the water reaches  $100^{\circ}\text{C}$ .

What is the correct symbol for a thermistor?

**[1 mark]**Tick (✓) **one** box.



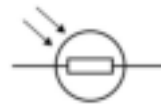





**0 7 . 3** The resistance of the heating element in the kettle is  $15 \Omega$ .

The current in the heating element is 12 A.

Calculate the power of the heating element.

Use the equation:

$$\text{power} = (\text{current})^2 \times \text{resistance}$$

**[2 marks]**

---

---

---

---

---

Power = \_\_\_\_\_ W

**Question 7 continues on the next page**



The student investigated how quickly the kettle could increase the temperature of 0.50 kg of water.

**Figure 10** shows the results of the investigation.

**Figure 10**

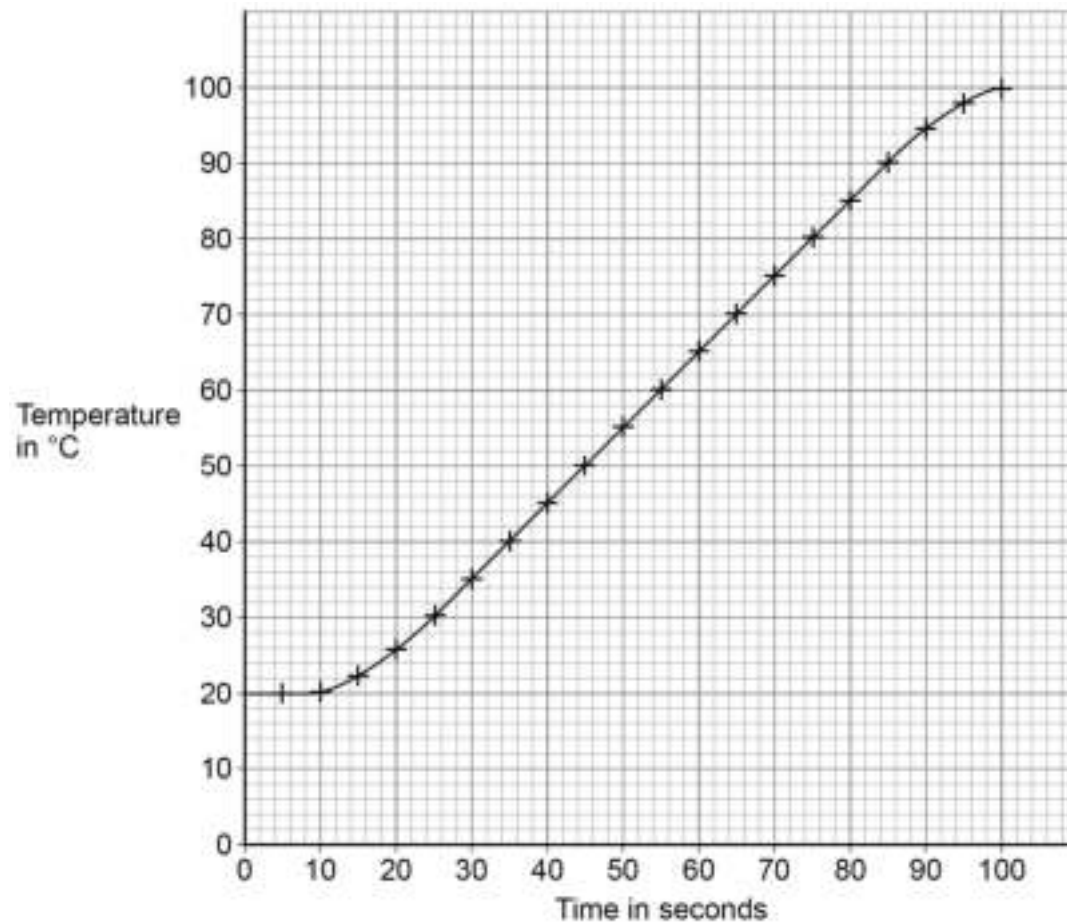

**0 7 . 4** The temperature of the water did **not** start to increase until 10 seconds after the kettle was switched on.

What is the reason for this?

**[1 mark]**

Tick (✓) **one** box.

Energy is transferred from the surroundings to the kettle.

The charge flows slowly through the kettle circuit.

The heating element in the kettle takes time to heat up.

The power output of the kettle increases slowly.

**0 7 . 5** Describe a method the student could have used to obtain the results shown in **Figure 10**.

**[6 marks]**

---

---

---

---

---

---

---

---

---

---

---

---

---

---

---

---

---

---

---

---

---

---

---

---

**Question 7 continues on the next page**

**Turn over ►**



**0 7 . 6** The mass of water in the kettle was 0.50 kg.

The temperature of the water increased from 20 °C to 100 °C.

specific heat capacity of water = 4200 J/kg °C

Calculate the energy transferred to the water.

Use the Physics Equations Sheet.

**[3 marks]**

---



---



---



---



---

Energy = \_\_\_\_\_ J

**0 7 . 7** The water in the kettle boiled for a short time before the kettle switched off.

During this time 5.0 g of water changed to steam.

specific latent heat of vaporisation of water = 2260 000 J/kg

Calculate the energy transferred to change the water to steam.

Use the Physics Equations Sheet.

**[3 marks]**

---



---



---



---



---

Energy = \_\_\_\_\_ J

**18**



**0 8**

A student investigated how the current in a filament lamp varied with the potential difference across the filament lamp.

**Figure 11** shows part of the circuit used.

**Figure 11**

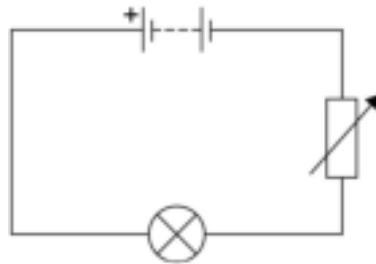
**0 8 . 1**

Complete **Figure 11** by adding an ammeter and a voltmeter.

Use the correct circuit symbols.

**[3 marks]**

**Question 8 continues on the next page**

**Turn over ►**



Figure 12 shows some of the results.

Figure 12

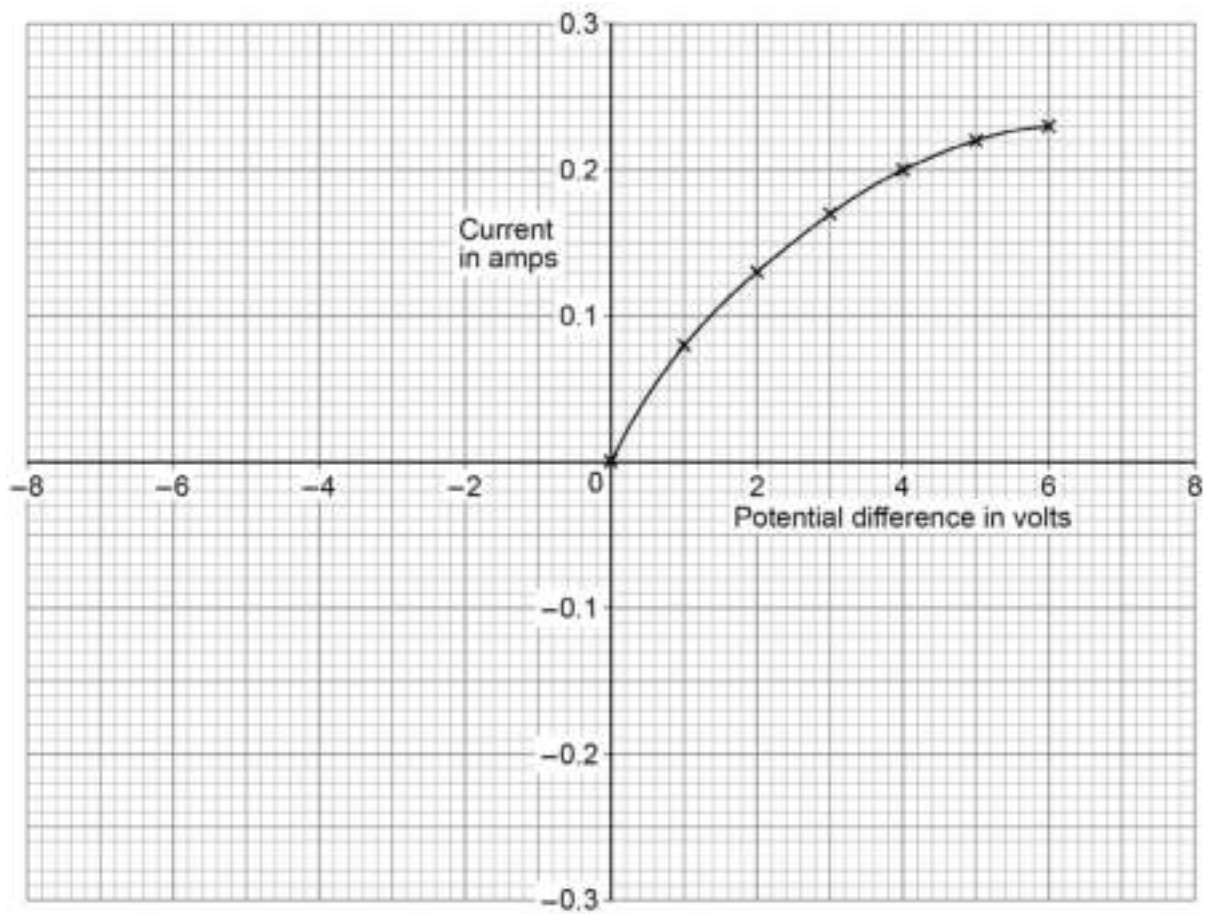

0 8 . 2 The student reversed the connections to the power supply and obtained negative values for the current and potential difference.

Draw a line on **Figure 12** to show the relationship between the negative values of current and potential difference.

[2 marks]



0 8 . 3

Write down the equation which links current ( $I$ ), potential difference ( $V$ ) and resistance ( $R$ ).

**[1 mark]**

---

0 8 . 4

Determine the resistance of the filament lamp when the potential difference across it is 1.0 V.

Use data from **Figure 12**.

**[4 marks]**

---

---

---

---

Resistance = \_\_\_\_\_  $\Omega$ 

0 8 . 5

A second student did the same investigation. The ammeter used had a zero error.

What is meant by a zero error?

**[1 mark]**

---

---

11

**Turn over for the next question****Turn over ►**

0 9

Figure 13 shows an LED torch.

Figure 13



0 9 . 1

The torch contains one LED, one switch and three cells.

Which diagram shows the correct circuit for the torch?

Tick (✓) **one** box.

[1 mark]

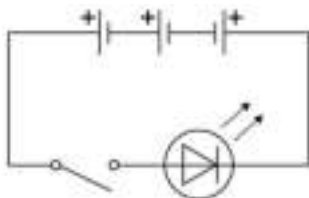

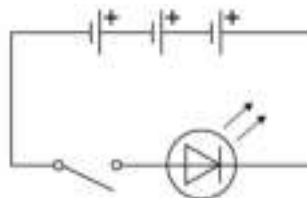

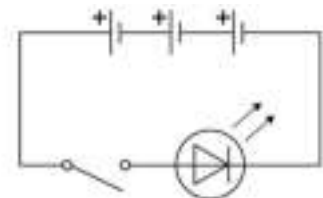





**0 9 . 2**Write down the equation which links charge flow ( $Q$ ), current ( $I$ ) and time ( $t$ ).**[1 mark]**

---

**0 9 . 3**

The torch worked for 14 400 seconds before the cells needed replacing.

The current in the LED was 50 mA.

Calculate the total charge flow through the cells.

**[3 marks]**

---

---

---

---

Total charge flow = \_\_\_\_\_ C

**0 9 . 4**

When replaced, the cells were put into the torch the wrong way around.

Explain why the torch did not work.

**[2 marks]**

---

---

---

---

---

---

**Question 9 continues on the next page****Turn over ►**

**0 9 . 5**

Write down the equation which links efficiency, total power input and useful power output.

**[1 mark]**

---

---

**0 9 . 6**

The total power input to the LED was 0.24 W.

The efficiency of the LED was 0.75

Calculate the useful power output of the LED.

**[3 marks]**

---

---

---

---

Useful power output = \_\_\_\_\_ W

**11**

**Turn over for the next question**

*Do not write  
outside the  
box*

**DO NOT WRITE ON THIS PAGE  
ANSWER IN THE SPACES PROVIDED**

**Turn over ►**



1 0

Figure 14 shows a hydroelectric power station.

Figure 14

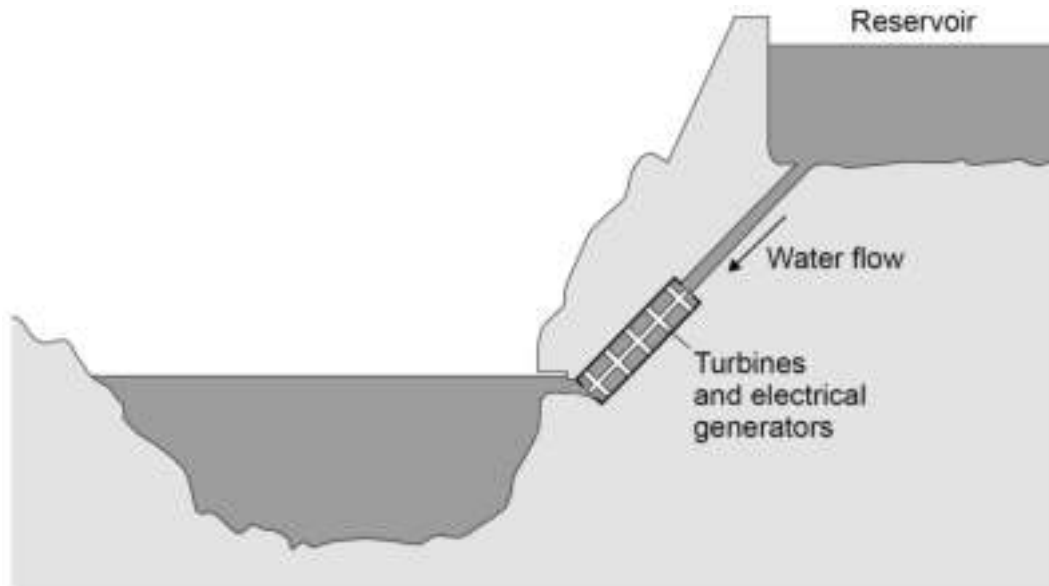

Electricity is generated when water from the reservoir flows through the turbines.

1 0 . 1

Write down the equation which links density ( $\rho$ ), mass ( $m$ ) and volume ( $V$ ).

[1 mark]

---

1 0 . 2

The reservoir stores 6 500 000 m<sup>3</sup> of water.

The density of the water is 998 kg/m<sup>3</sup>.

Calculate the mass of water in the reservoir.

Give your answer in standard form.

[4 marks]

---



---



---



---



---

Mass (in standard form) = \_\_\_\_\_ kg



1 0 . 3

Write down the equation which links energy transferred ( $E$ ), power ( $P$ ) and time ( $t$ ).**[1 mark]**

---

1 0 . 4

The electrical generators can provide  $1.5 \times 10^9$  W of power for a maximum of 5 hours.

Calculate the maximum energy that can be transferred by the electrical generators.

**[3 marks]**

---

---

---

---

---

Energy transferred = \_\_\_\_\_ J

**Question 10 continues on the next page**

1 0 . 5

**Figure 15** shows how the UK demand for electricity increases and decreases during one day.

**Figure 15**

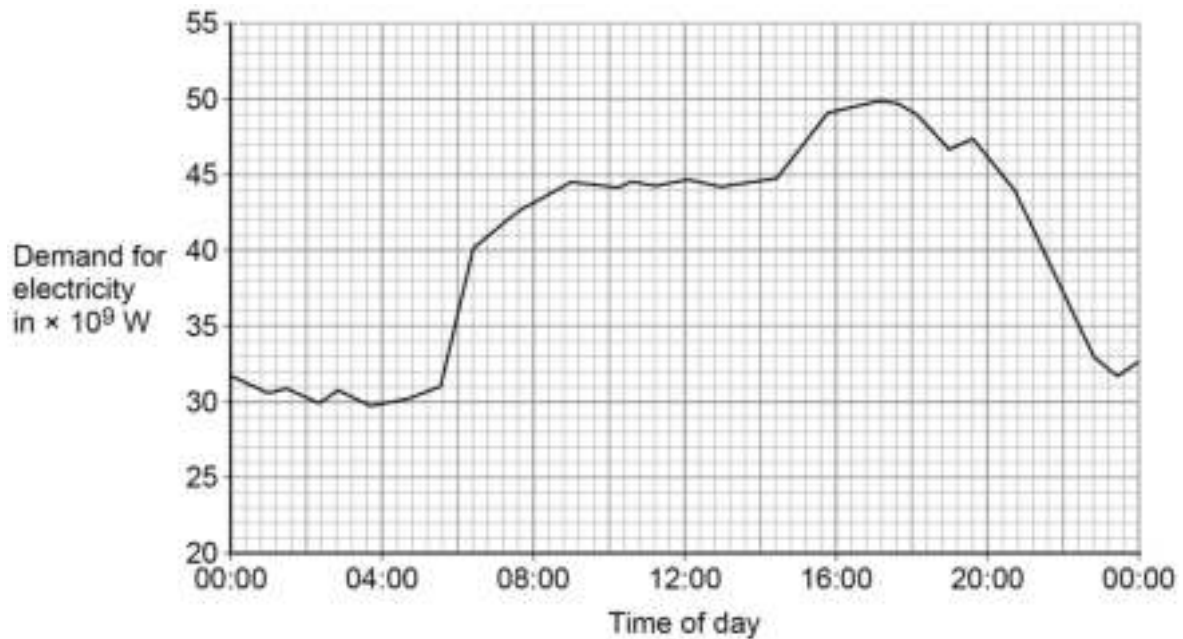

The hydroelectric power station in **Figure 14** can provide  $1.5 \times 10^9$  W of power for a maximum of 5 hours.

Give **two** reasons why this hydroelectric power station is not able to meet the increase in demand shown between 04:00 and 16:00 in **Figure 15**.

[2 marks]

1 \_\_\_\_\_

\_\_\_\_\_

\_\_\_\_\_

2 \_\_\_\_\_

\_\_\_\_\_

\_\_\_\_\_

11

**END OF QUESTIONS**



**There are no questions printed on this page**

*Do not write  
outside the  
box*

**DO NOT WRITE ON THIS PAGE  
ANSWER IN THE SPACES PROVIDED**











Question number	<p style="text-align: center;"><b>Additional page, if required.</b></p> <p style="text-align: center;"><b>Write the question numbers in the left-hand margin.</b></p>



**There are no questions printed on this page**

*Do not write  
outside the  
box*

**DO NOT WRITE ON THIS PAGE  
ANSWER IN THE SPACES PROVIDED**

**Copyright information**

For confidentiality purposes, all acknowledgements of third-party copyright material are published in a separate booklet. This booklet is published after each live examination series and is available for free download from [www.aqa.org.uk](http://www.aqa.org.uk).

Permission to reproduce all copyright material has been applied for. In some cases, efforts to contact copyright-holders may have been unsuccessful and AQA will be happy to rectify any omissions of acknowledgements. If you have any queries please contact the Copyright Team.

Copyright © 2020 AQA and its licensors. All rights reserved.

