

Surname	Centre Number	Candidate Number
First name(s)		0



**GCSE**

3300U50-1



**MONDAY, 14 NOVEMBER 2022 – MORNING**

**MATHEMATICS  
UNIT 1: NON-CALCULATOR  
HIGHER TIER**

1 hour 45 minutes

**ADDITIONAL MATERIALS**

The use of a calculator is not permitted in this examination.  
A ruler, a protractor and a pair of compasses may be required.

**INSTRUCTIONS TO CANDIDATES**

Use black ink or black ball-point pen. Do not use gel pen or correction fluid.

You may use a pencil for graphs and diagrams only.

Write your name, centre number and candidate number in the spaces at the top of this page.

Answer **all** the questions in the spaces provided.

If you run out of space, use the additional page at the back of the booklet. Question numbers must be given for all work written on the additional page.

Take  $\pi$  as 3.14.

**INFORMATION FOR CANDIDATES**

You should give details of your method of solution when appropriate.

Unless stated, diagrams are not drawn to scale.

Scale drawing solutions will not be acceptable where you are asked to calculate.

The number of marks is given in brackets at the end of each question or part-question.

In question **10**, the assessment will take into account the quality of your organisation, communication and accuracy in writing.

For Examiner's use only		
Question	Maximum Mark	Mark Awarded
1.	5	
2.	3	
3.	3	
4.	6	
5.	5	
6.	3	
7.	4	
8.	2	
9.	4	
10.	6	
11.	6	
12.	3	
13.	3	
14.	3	
15.	4	
16.	3	
17.	3	
18.	4	
19.	3	
20.	2	
21.	5	
<b>Total</b>	<b>80</b>	



NOV223300U50101

## Formula List – Higher Tier

$$\text{Area of trapezium} = \frac{1}{2} (a + b)h$$

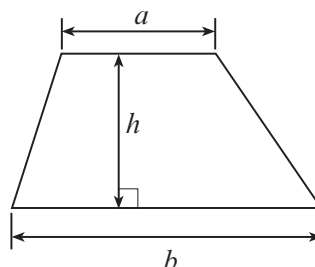

$$\text{Volume of prism} = \text{area of cross-section} \times \text{length}$$

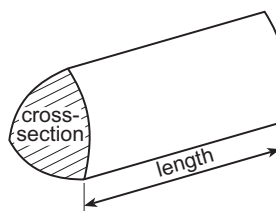

$$\text{Volume of sphere} = \frac{4}{3} \pi r^3$$

$$\text{Surface area of sphere} = 4\pi r^2$$

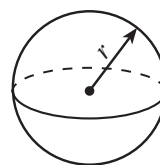

$$\text{Volume of cone} = \frac{1}{3} \pi r^2 h$$

$$\text{Curved surface area of cone} = \pi r l$$

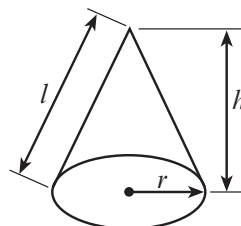

In any triangle  $ABC$

$$\text{Sine rule} \quad \frac{a}{\sin A} = \frac{b}{\sin B} = \frac{c}{\sin C}$$

$$\text{Cosine rule} \quad a^2 = b^2 + c^2 - 2bc \cos A$$

$$\text{Area of triangle} = \frac{1}{2} ab \sin C$$

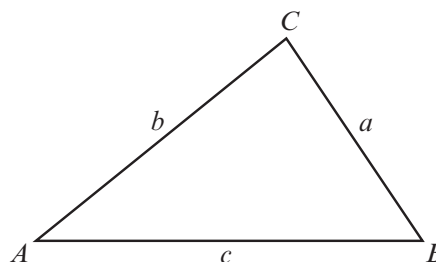

### The Quadratic Equation

The solutions of  $ax^2 + bx + c = 0$  where  $a \neq 0$  are given by 
$$x = \frac{-b \pm \sqrt{(b^2 - 4ac)}}{2a}$$

### Annual Equivalent Rate (AER)

AER, as a decimal, is calculated using the formula  $\left(1 + \frac{i}{n}\right)^n - 1$ , where  $i$  is the nominal interest rate per annum as a decimal and  $n$  is the number of compounding periods per annum.



1. In a group of 200 people:
- 105 people do not have black hair and do not wear glasses
  - 20 people have black hair and wear glasses
  - 70 people have black hair.

(a) Complete the Venn diagram below to show this information.  
The universal set,  $\mathcal{E}$ , contains all 200 people.

[3]

.....

.....

.....

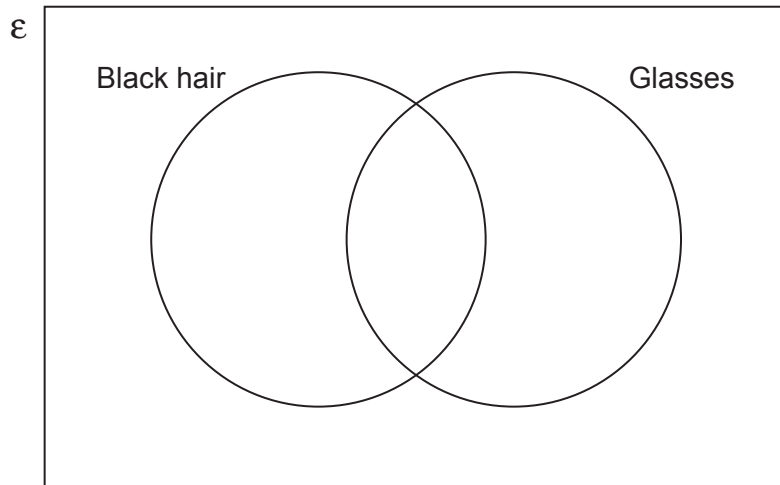

(b) One of these people is chosen at random.  
What is the probability that this person wears glasses?

[2]

.....

.....

.....

.....



2. Triangle  $ABC$  is shown in the diagram below.  
Using only a ruler and a pair of compasses, construct an accurate drawing of triangle  $ABC$ .  
Side  $AC$  has been drawn for you.  
All construction lines and arcs must be shown. [3]

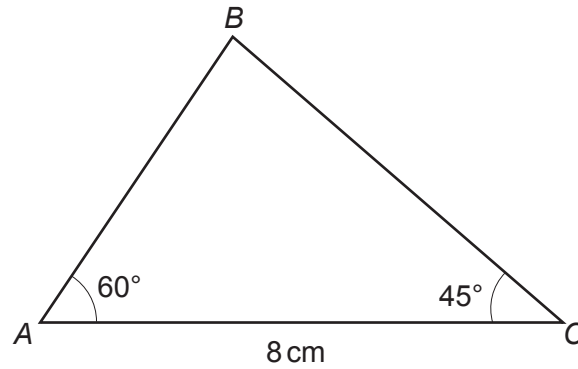

*Diagram not drawn to scale*

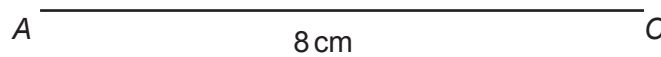

3. Express 1575 as a product of its prime factors in index form.

[3]

.....

.....

.....

.....

.....

.....

.....

.....

.....

.....

.....

.....

.....

.....

.....

.....

.....

.....

.....

.....

.....

.....

.....

4. Simplify the following expressions.

(a)  $2p^3q \times 3p^4q^7$

[2]

.....

.....

(b)  $7a(a+5) - 2(3a^2 + 6a - 7)$

[4]

.....

.....

.....

.....

.....

.....

.....

.....

.....

.....

.....

.....

.....

.....

.....

.....

.....

.....

.....

.....

.....

.....

.....



5. The diagram below shows the graph of a straight line for values of  $x$  from  $-1$  to  $3$ .

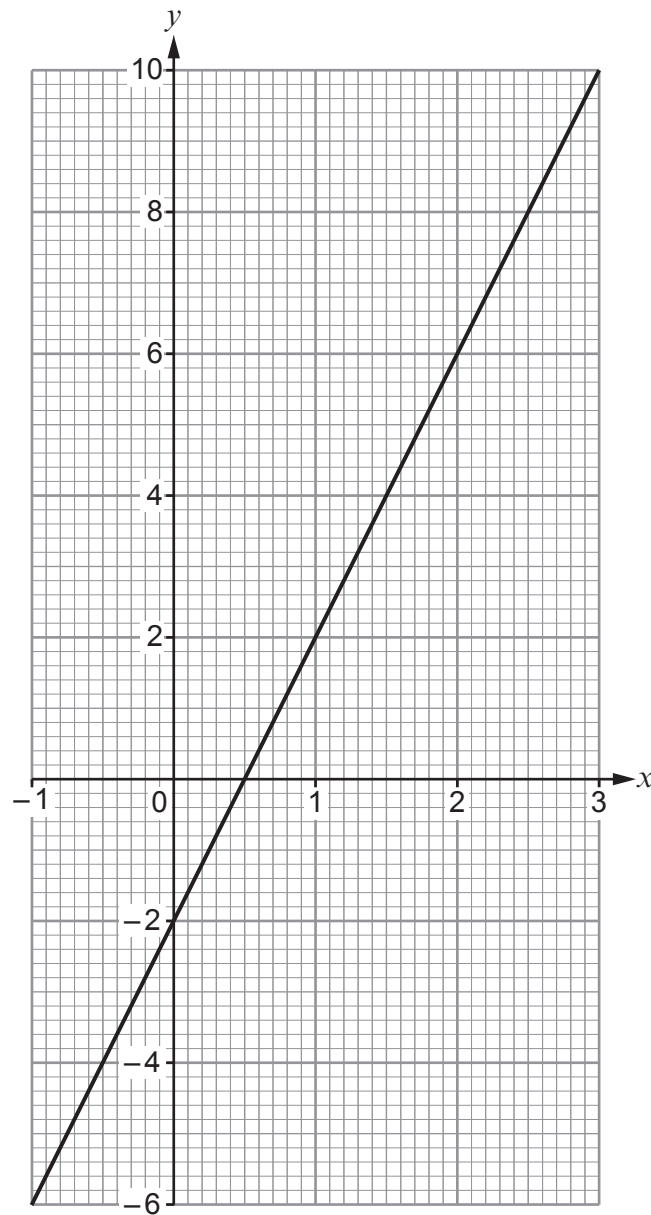

- (a) (i) Write down the gradient of the line above.

[1]

.....  
.....



(ii) Write down the equation of the line in the form  $y = mx + c$  .

[2]

.....

.....

(b) Show that the lines

$$y = 3x - 8 \quad \text{and} \quad 2y - 6x = 23$$

are parallel to each other.

[2]

.....

.....

.....

.....

.....

.....

.....

.....

.....



6. In the following formulae, each measurement of length is represented by a letter. Consider the dimensions implied by each formula. For each case, write down whether the formula could be for a length, an area, a volume or none of these.

The first one has been done for you.

[3]

<u>Formula</u>	<u>Formula could be for</u>
$7a^3 - abc$	volume
$7ab - 5b^2 + \frac{a^2b}{c}$	.....
$5abc - 6bc + b^2$	.....
$4a^2b + 4b^2a$	.....
$3a + 8b + 2c$	.....
$a^2 - abc$	.....





7. (a) Calculate the value of  $(3 \times 10^4) \div (6 \times 10^{-3})$ .  
Give your answer in standard form.

[2]

.....

.....

.....

.....

.....

.....

- (b) Calculate the value of  $(4.78 \times 10^4) + (1.5 \times 10^2)$ .  
Give your answer in standard form.

[2]

.....

.....

.....

.....

.....

.....



8. (a) Which complete method, using Pythagoras's Theorem, can be used to find  $x$ ?  
Circle your answer.

[1]

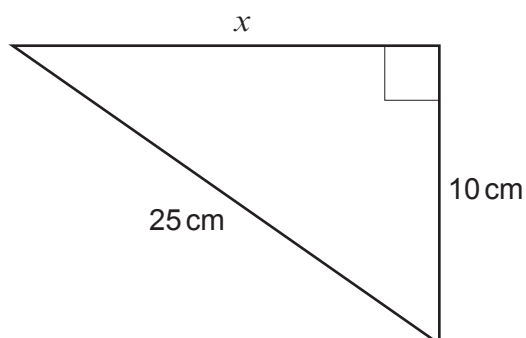

*Diagram not drawn to scale*

$$x = 25^2 + 10^2$$

$$x = \sqrt{25^2 + 10^2}$$

$$x = 25^2 - 10^2$$

$$x = \sqrt{25^2 - 10^2}$$

$$x = \sqrt{(25 - 10)^2}$$

- (b) Which of the following calculations can be used to find  $y$ ?  
Circle your answer.

[1]

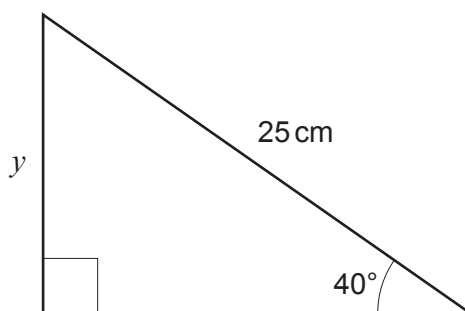

*Diagram not drawn to scale*

$$\sin 25^\circ = y \times 40$$

$$\sin 40^\circ = \frac{25}{y}$$

$$\sin 25^\circ = \frac{y}{40}$$

$$\sin 40^\circ = \frac{y}{25}$$

$$\sin 40^\circ = y \times 25$$



9.  $P$ ,  $Q$  and  $R$  are points on the circumference of a circle with centre  $O$ .

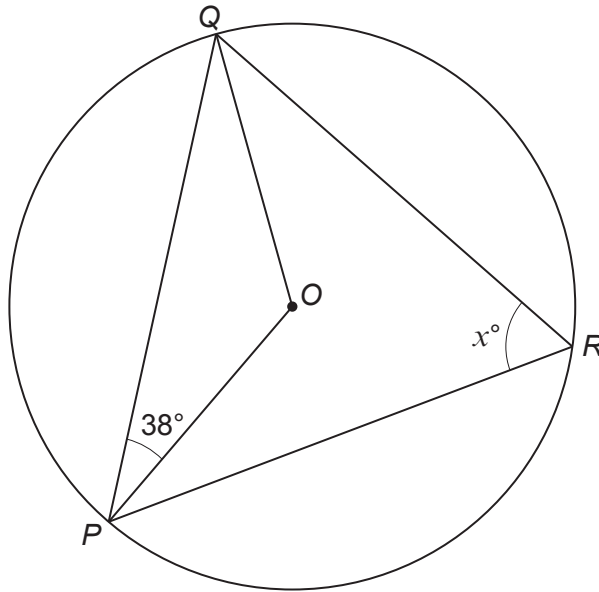

Diagram not drawn to scale

Calculate the value of  $x$ .  
You must state **all** the angle properties that you use.  
You must show all your working.

[4]

.....

.....

.....

.....

.....

.....

.....

.....

.....

.....

.....

.....

.....

.....

.....

.....



10. *In this question, you will be assessed on the quality of your organisation, communication and accuracy in writing.*

On Monday morning, Twm picked  $n$  apples from a tree.  
Ceri picked 5 times as many apples as Twm.

On Monday afternoon, Twm picked 19 more apples.  
Ceri gave 7 of her apples to Twm.

Ceri still had more apples than Twm.

Write down an inequality in terms of  $n$  to show the above information.  
Use your inequality to find the least possible number of apples Twm picked on Monday morning.

You must show all your working. [4 + 2 OCW]

.....

.....

.....

.....

.....

.....

.....

.....

.....

.....

.....

.....

.....

.....

.....

.....

.....

.....

.....

.....

.....

.....

.....



11. (a) Given that  $y$  is **directly** proportional to  $x^3$  and that  $y = 108$  when  $x = 3$ ,

(i) find an expression for  $y$  in terms of  $x$ .

[3]

.....

.....

.....

.....

.....

.....

.....

(ii) Use the expression you found in part (i) to complete the following table.

[2]

$x$	3	5	
$y$	108		4000

.....

.....

.....

.....

.....

.....

.....

(b) It is known that  $e$  is **inversely** proportional to  $f$ .  
Describe what happens to  $e$  when  $f$  is doubled.

[1]

.....

.....

.....



12. Describe fully the **single** transformation that transforms shape A onto shape B. [3]

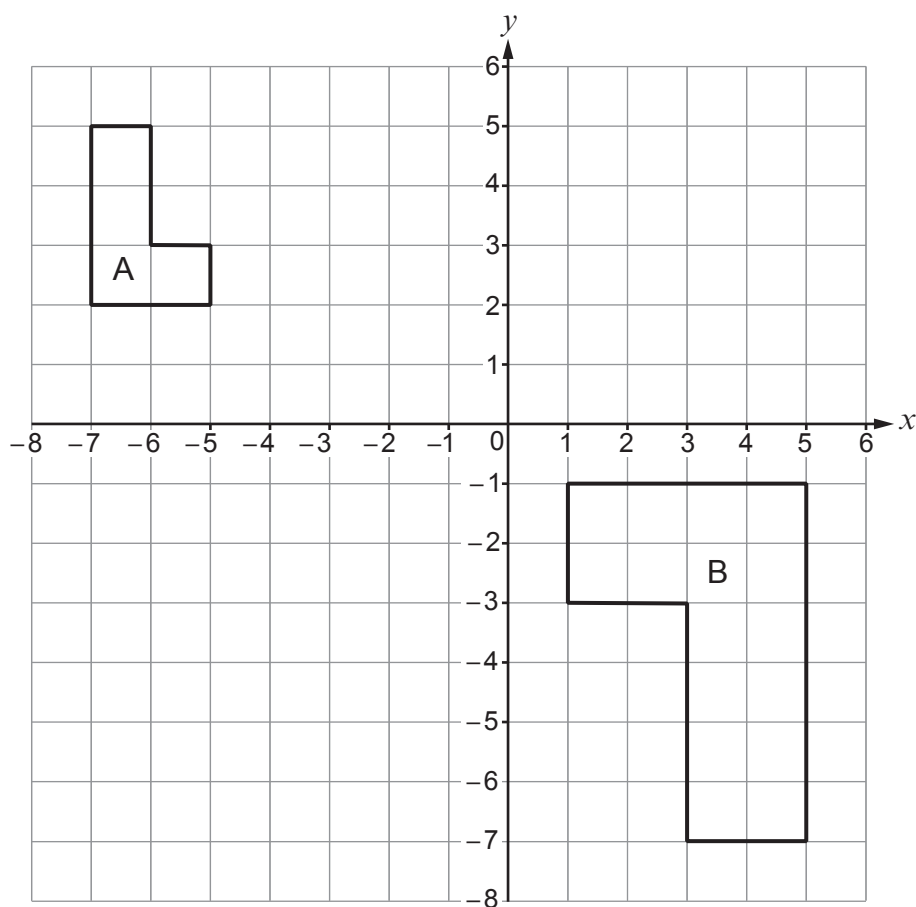

.....

.....

.....

.....

.....

.....

.....

.....

.....

.....

.....



13. In the following diagram, the lines  $AC$  and  $BD$  bisect each other.

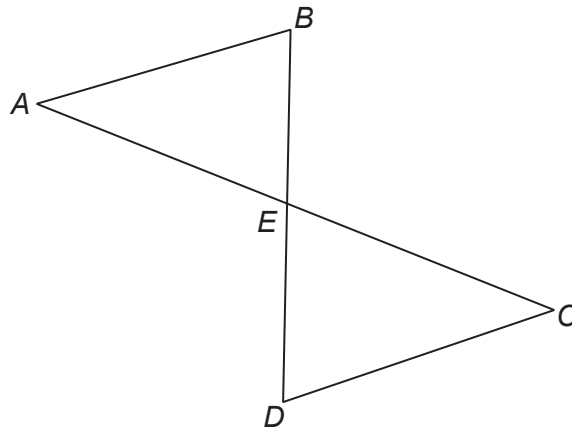

*Diagram not drawn to scale*

Prove that triangles  $ABE$  and  $CDE$  are congruent.  
You must state the condition of congruence.

[3]

.....

.....

.....

.....

.....

.....

.....

.....

.....

.....

.....

.....

.....

.....

.....

.....

.....

.....

.....

.....

.....

.....



14. Using the axes below, find the region which satisfies the following inequalities.

$$y \leq \frac{1}{2}x + 1$$

$$y + x \geq 0$$

$$x \leq 3$$

You must clearly indicate the region that represents your answer.

[3]

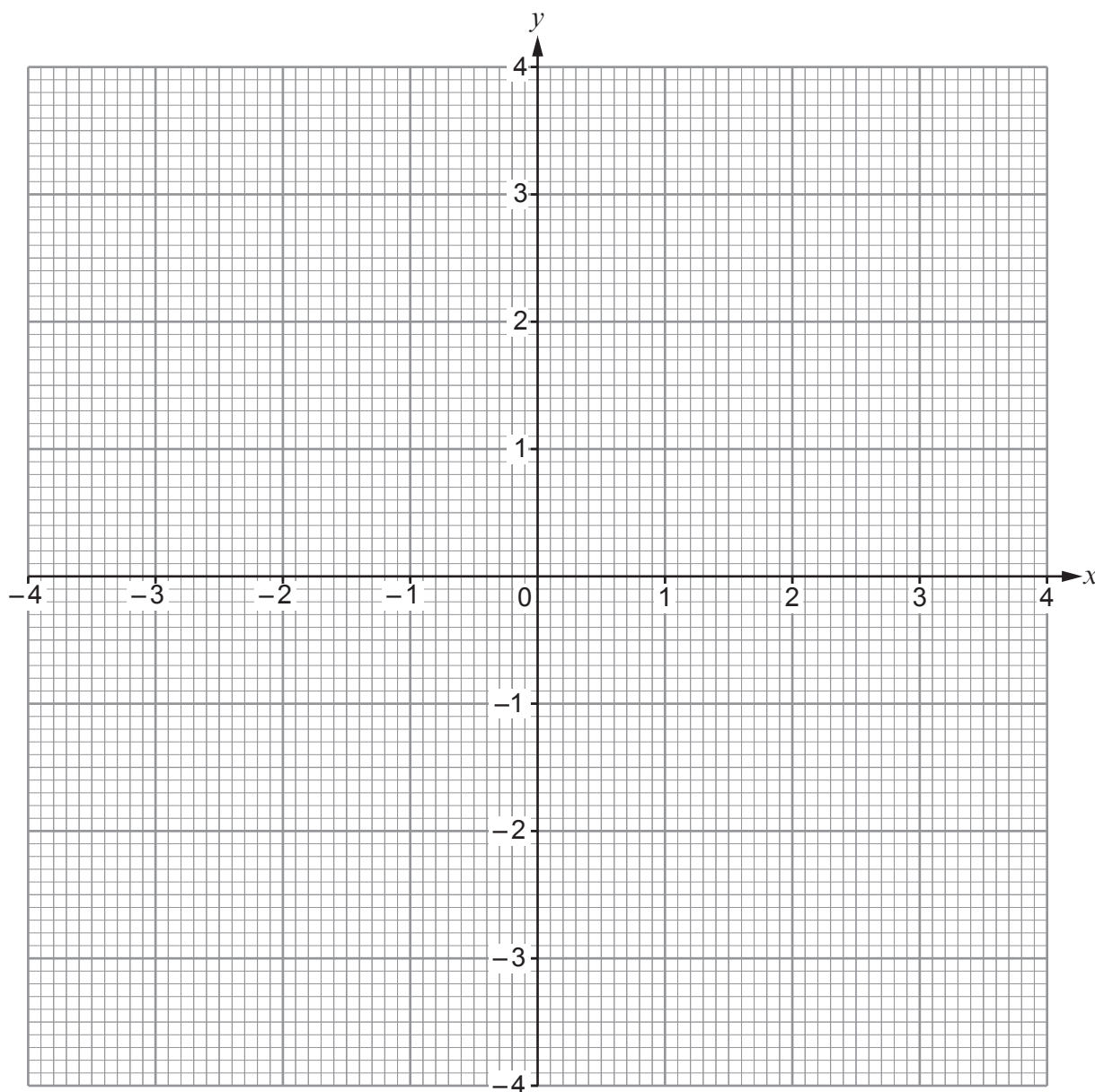



15. (a) Express  $0.\dot{6}54$  as a fraction.

[2]

.....

.....

.....

.....

.....

.....

.....

.....

.....

.....

.....

.....

.....

.....

.....

.....

.....

.....

.....

.....

.....

.....

.....

(b) Evaluate  $27^{-\frac{2}{3}}$ .

[2]

.....

.....

.....

.....

.....

.....

.....

.....

.....

.....

.....

.....

.....

.....

.....

.....

.....

.....

.....

.....

.....

.....



**16.** A cone and a cylinder have equal volumes.

The cone has a base radius of  $r$  cm and a height of  $h$  cm.

The cylinder has a base radius of  $r$  cm and a height of  $\frac{3}{2}r$  cm.

Find  $h$  in terms of  $r$ .

You must express your answer in its simplest form.

[3]

---

---

---

---

---

---

---

---

---

---

---

---

---

---

---

---

---

---

---

---

---

---

---

---

---

---



17. Evaluate the mean of the following three numbers:

$$\sqrt{20} \quad (\sqrt{5})^3 \quad 11\sqrt{5}$$

Express your answer in the form  $a\sqrt{5}$ , where  $a$  is an integer.

[3]

.....

.....

.....

.....

.....

.....

.....

.....

.....

.....

.....

.....

.....

.....

.....

.....

.....

.....

.....

.....

.....

.....

.....



**18.** Ffion has some blue cards and some yellow cards.  
She takes 7 of the blue cards and 3 of the yellow cards and puts them in a box.

Ffion removes one card from the box at random and replaces it with **two** cards of the other colour.

Then she removes a second card from the box at random.

Calculate the probability that the two cards that Ffion removed are of different colours. [4]

.....

.....

.....

.....

.....

.....

.....

.....

.....

.....

.....

.....

.....

.....

.....

.....

.....

.....

.....

.....

.....

.....



19. The highest point of a curve is called a maximum point.  
The diagram below shows a sketch of the curve with equation  $y = f(x)$ .  
The maximum point of this curve has coordinates  $(-5, 4)$ .

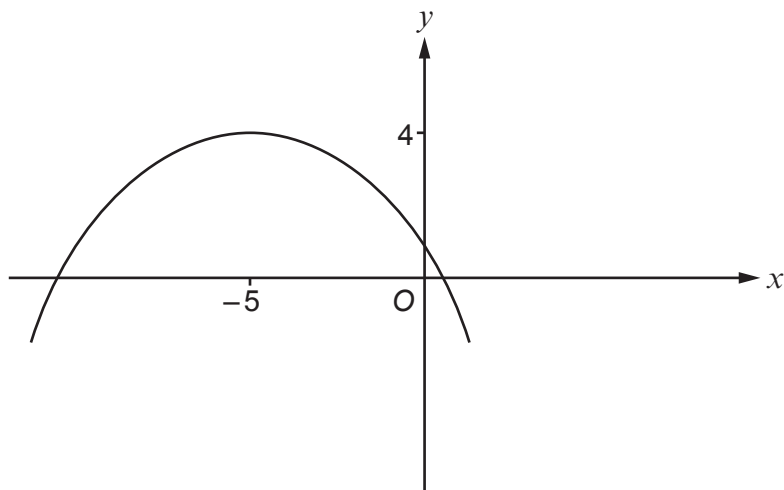

- (a) For each of the following, write down the coordinates of the maximum point of the curve with the given equation.

(i)  $y = 2f(x)$  [1]

The coordinates of the maximum point are ( ..... , ..... ).

(ii)  $y = f(x-7)$  [1]

The coordinates of the maximum point are ( ..... , ..... ).

- (b) The curve with equation  $y = f(x)$  is reflected in the  $y$ -axis.  
Write down the equation of the transformed curve.  
You should use function notation. [1]

The equation of the transformed curve is

$$y = \dots\dots\dots$$



20. The following diagram shows a sketch of  $y = \cos x$  for values of  $x$  from  $0^\circ$  to  $360^\circ$ .

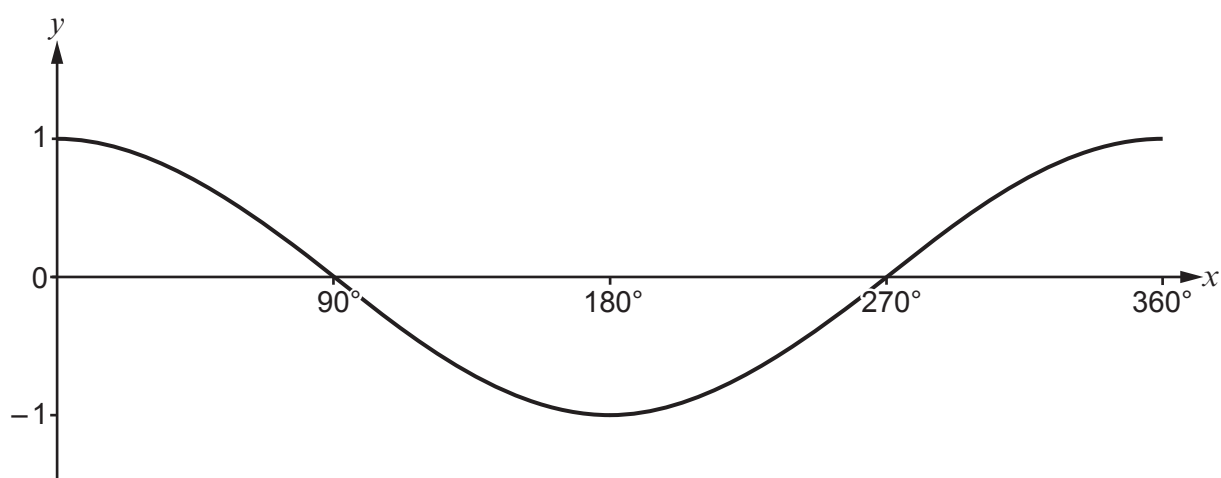

Given that  $\cos 25^\circ = 0.9063$ , correct to 4 decimal places, write down all the solutions of the equation

$$\cos x = -0.9063$$

for values of  $x$  from  $0^\circ$  to  $360^\circ$ .

[2]

.....

.....

.....

.....

.....

.....

.....

.....

.....

.....



21. Solve the following equation.  
Do not use a trial and improvement method.

[5]

$$\frac{x}{x+1} = \frac{2}{4x-5}$$

.....

.....

.....

.....

.....

.....

.....

.....

.....

.....

.....

.....

.....

.....

.....

.....

.....

.....

.....

.....

.....

.....

**END OF PAPER**



