

Please write clearly in block capitals.

Centre number

--	--	--	--	--

Candidate number

--	--	--	--

Surname

Forename(s)

Candidate signature

I declare this is my own work.

GCSE COMBINED SCIENCE: TRILOGY

F

Foundation Tier
Chemistry Paper 2F

Time allowed: 1 hour 15 minutes

Materials

For this paper you must have:

- a ruler
- a scientific calculator
- the periodic table (enclosed).

Instructions

- Use black ink or black ball-point pen.
- Pencil should only be used for drawing.
- Fill in the boxes at the top of this page.
- Answer **all** questions in the spaces provided.
- If you need extra space for your answer(s), use the lined pages at the end of this book. Write the question number against your answer(s).
- Do all rough work in this book. Cross through any work you do not want to be marked.
- In all calculations, show clearly how you work out your answer.

Information

- The maximum mark for this paper is 70.
- The marks for questions are shown in brackets.
- You are expected to use a calculator where appropriate.
- You are reminded of the need for good English and clear presentation in your answers.

For Examiner's Use	
Question	Mark
1	
2	
3	
4	
5	
6	
7	
TOTAL	



0 1

This question is about the Earth's atmosphere.

0 1 . 1

The Earth's atmosphere contains 21% oxygen.

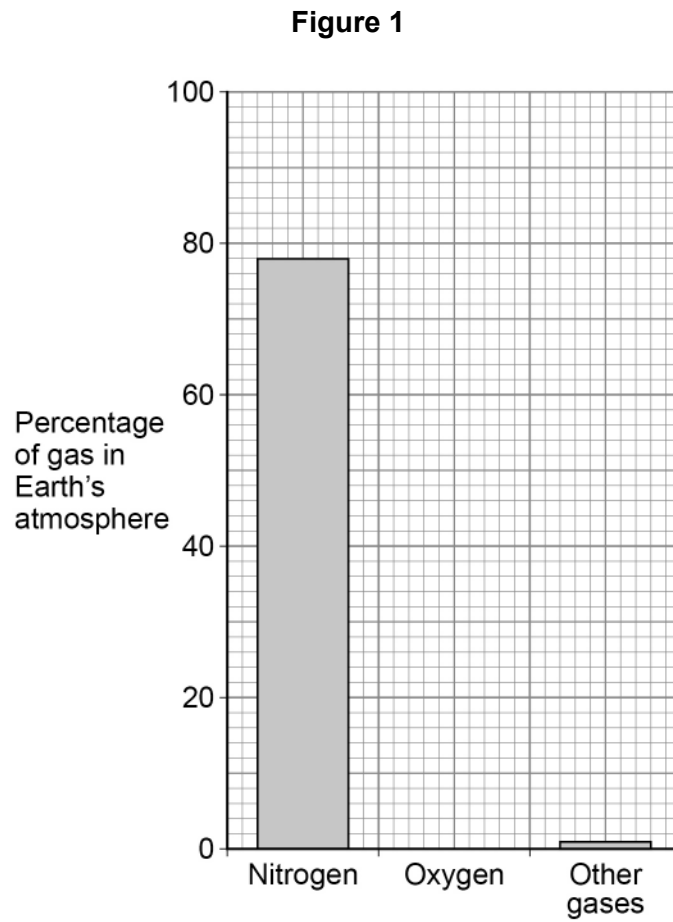
Draw the bar for oxygen on **Figure 1**.**[1 mark]**

0 1 . 2

What is used to test for oxygen gas?

[1 mark]Tick (✓) **one** box.

A burning splint

A glowing splint

Damp litmus paper

Limewater



The Earth's early atmosphere was very different from the Earth's atmosphere today.

Figure 2 shows the composition of the Earth's early atmosphere and of the Earth's atmosphere today.

Figure 2

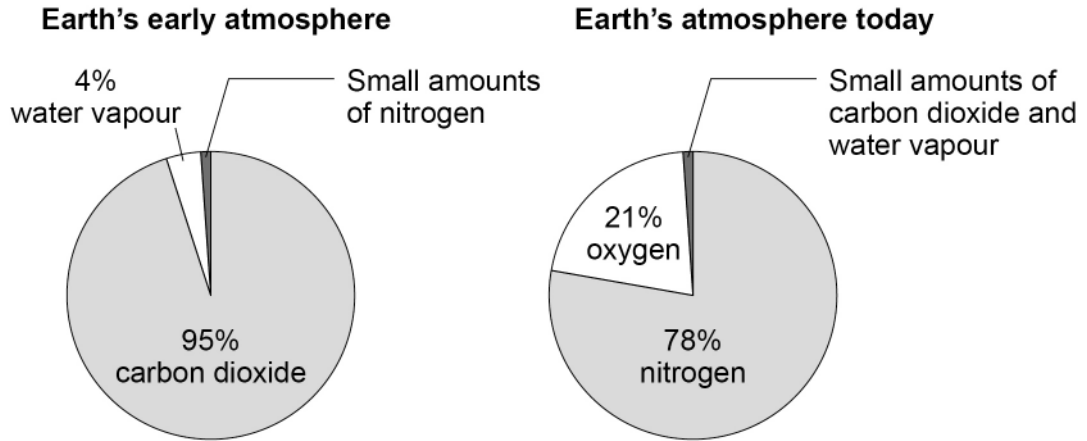

0 1 3

The percentages of nitrogen and oxygen in the Earth's atmosphere today are different from the Earth's early atmosphere.

Complete the sentences.

Choose answers from the box.

Use **Figure 2**.

Each answer can be used once, more than once or not at all.

[2 marks]

decreased increased stayed the same

Since the Earth's early atmosphere, the percentage of nitrogen in the Earth's atmosphere has _____.

Since the Earth's early atmosphere, the percentage of oxygen in the Earth's atmosphere has _____.

Turn over ►



0 1 . 4

The Earth's atmosphere today contains a small amount of carbon dioxide.

Why has the percentage of carbon dioxide decreased since the Earth's early atmosphere?

[2 marks]

Tick (✓) **two** boxes.

Dissolved in oceans

Formation of sedimentary rocks

Industrialisation

Respiration

Volcanic activity



Oxides of nitrogen are produced when nitrogen reacts with oxygen in car engines.

Figure 3 shows the concentration of oxides of nitrogen in the atmosphere during one day in a city.

Figure 3

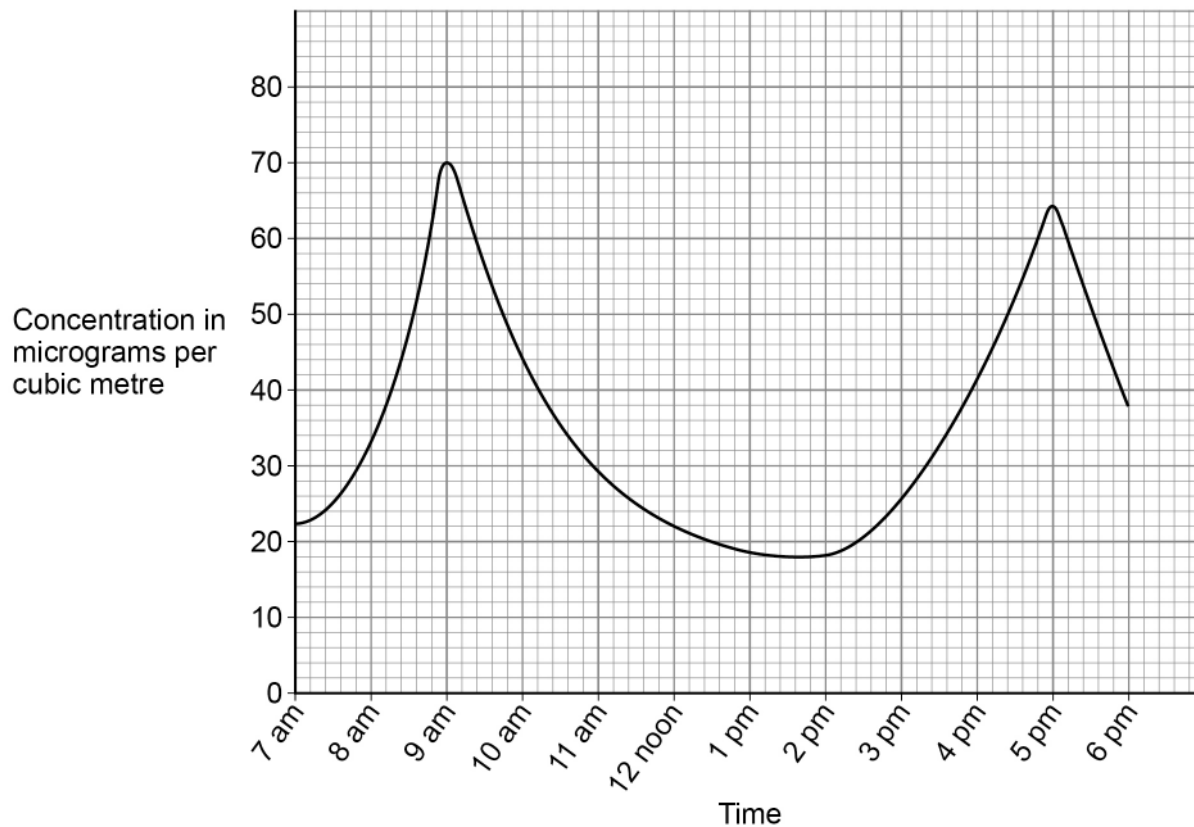

0 1 . 5

Which **two times** have the highest concentrations of oxides of nitrogen in the atmosphere?

[2 marks]

1 _____

2 _____

0 1 . 6

Suggest why there are the highest concentrations of oxides of nitrogen at these times.

[1 mark]



0 2

This question is about fuels.

Coal deposits were formed from the remains of trees.

0 2 . 1

Name the process in the leaves of trees that uses carbon dioxide.

[1 mark]

0 2 . 2

How is coal formed after trees die?

[1 mark]

Tick (✓) **one** box.

The trees are burned.

The trees are compressed.

The trees are melted.

Coal contains small amounts of sulfur.

0 2 . 3

Name the gas produced when sulfur burns in oxygen.

[1 mark]

0 2 . 4

Give **two** problems caused by the gas produced when sulfur burns in oxygen.

[2 marks]

1 _____

2 _____



0 2 . 5

Figure 4 shows the relative amount of electricity generated from different fuel sources in the UK from 2012 to 2018.

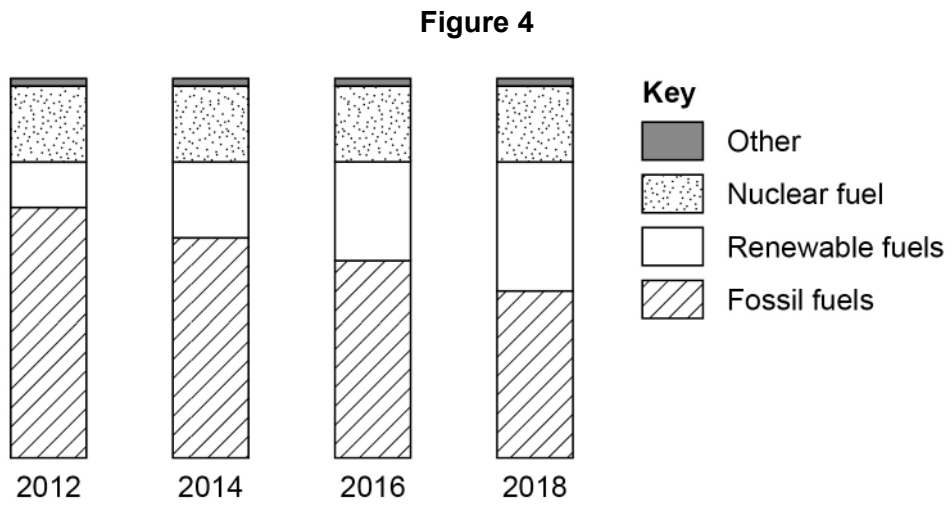

Describe what happens to the amounts of fuels used to generate electricity in the UK from 2012 to 2018.

[3 marks]

8

Turn over for the next question

Turn over ►



0 3

This question is about ammonia and its compounds.

A student heated a sample of ammonium chloride.

The equation for the reaction is:

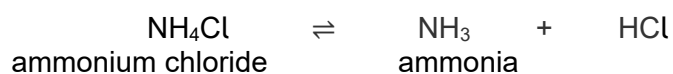

0 3 . 1

One product is ammonia.

What is the name of the product with the formula HCl?

[1 mark]

0 3 . 2

Ammonia is a gas.

What is the state symbol for ammonia?

[1 mark]

Tick (✓) **one** box.

(aq)

(g)

(l)

(s)

0 3 . 3

How does the equation show that the reaction is reversible?

[1 mark]

0 3 . 4

Complete the sentence.

[1 mark]

The forward reaction is endothermic,

so the reverse reaction is _____.



0 3 . 5 Complete the sentence.

Choose the answer from the box.

[1 mark]

concentration

rate

temperature

Equilibrium is reached when the forward and reverse reactions happen at exactly the same _____.

Question 3 continues on the next page

Turn over ►



The industrial process to produce ammonia uses a catalyst.

0 3 . 6 **Figure 5** shows the reaction profile for the reaction with and without a catalyst.

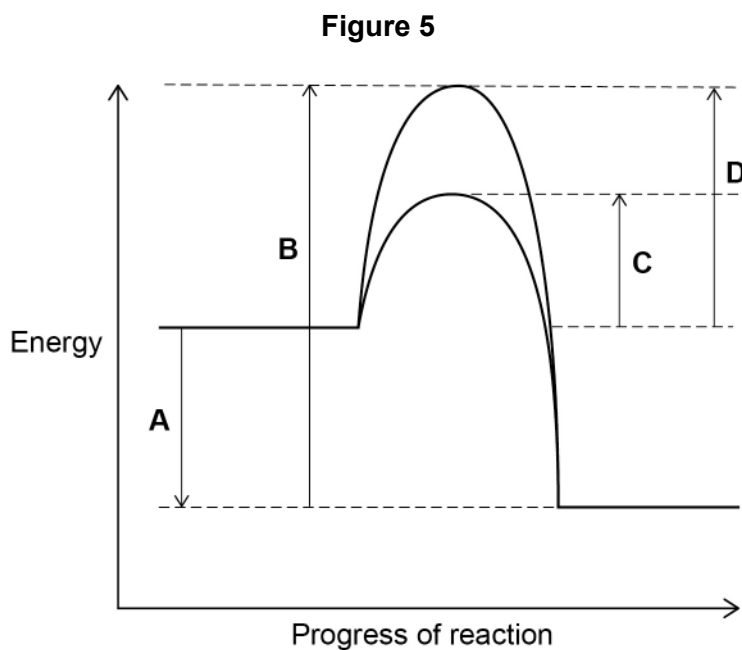

Which letter represents the activation energy for the reaction with a catalyst?

[1 mark]

Tick (✓) **one** box.

A B C D



0 3 . 7 Give **one** reason why using a catalyst reduces costs.

Do **not** answer in terms of activation energy.

[1 mark]

0 3 . 8 Ammonia is in a mixture that is used as a household cleaner.

What is a mixture that has been designed as a useful product called?

[1 mark]

8

Turn over for the next question

Turn over ►



0 4

A student investigates the effect of concentration on the rate of the reaction between sodium thiosulfate solution and hydrochloric acid.

Figure 6 shows the experiment.

The experiment was done in a fume cupboard.

Figure 6

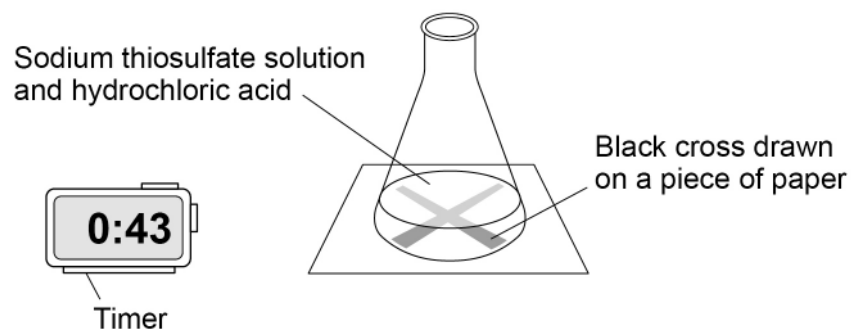

This is the method used.

1. Pour 50 cm³ of sodium thiosulfate solution into a conical flask.
2. Put the conical flask on a black cross drawn on a piece of paper.
3. Pour 10 cm³ of hydrochloric acid into the conical flask and start a timer.
4. Stop the timer when the cross can no longer be seen.
5. Repeat the experiment with different concentrations of sodium thiosulfate solution.



0 4 . 1

Draw **one** line from each type of variable to the correct example of the variable in this investigation.

[2 marks]**Type of variable****Example of variable**

Dependent

Concentration of sodium
thiosulfate solutionTemperature of reaction
mixtureTime taken for the cross
to no longer be seen

Independent

Volume of acid

Volume of the flask

Question 4 continues on the next page**Turn over ►**

0 4 . 2 The experiment is done at room temperature.

Figure 7

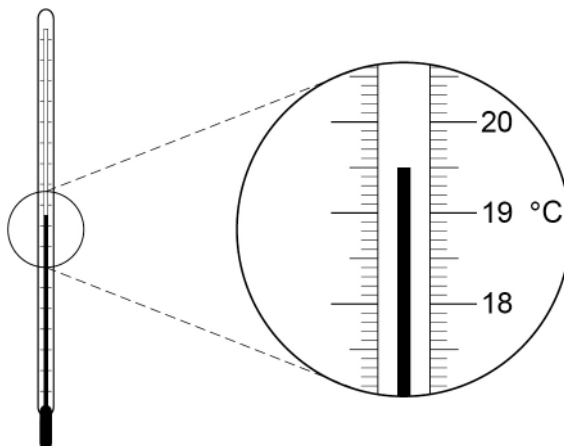

What is the temperature shown on the thermometer in **Figure 7**?

[1 mark]

Temperature = _____ °C

Table 1 shows the student's results.

Table 1

Concentration of sodium thiosulfate solution in mol/dm ³	Time in seconds
0.1	82
0.2	40
0.3	20
0.4	13
0.5	10
0.6	8



0 4 . 3 Plot the data from **Table 1** on **Figure 8**.

Draw a line of best fit.

[3 marks]

Figure 8

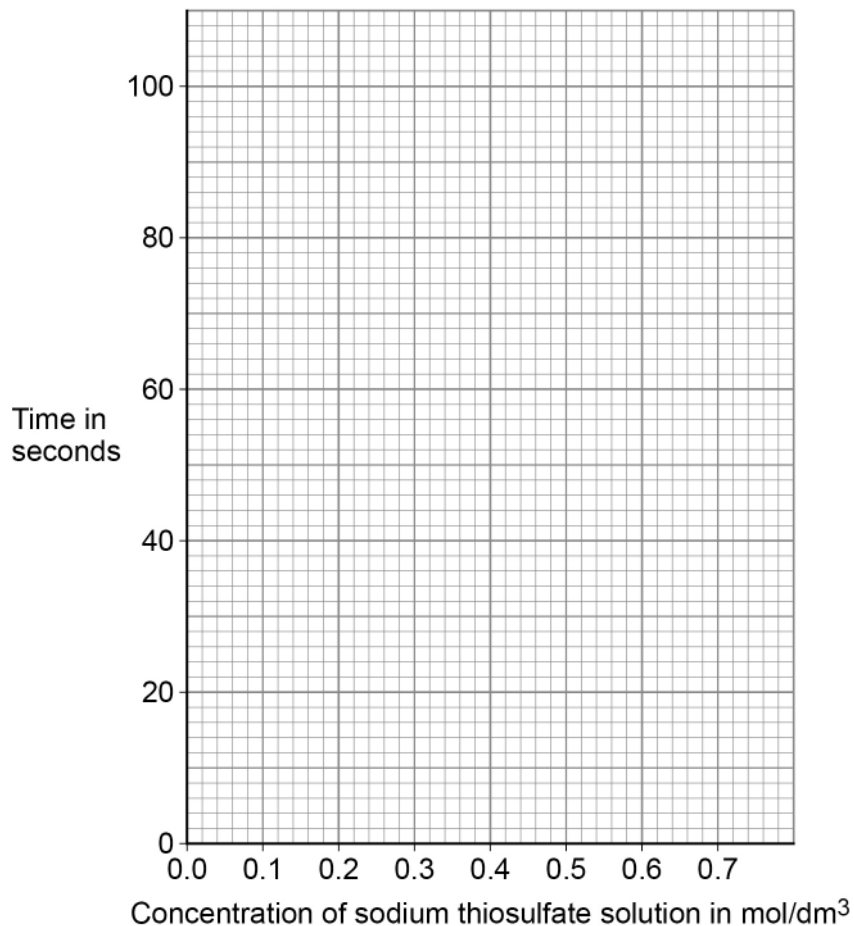

0 4 . 4 Predict the time taken for the cross to no longer be seen at a concentration of 0.7 mol/dm^3

Use your graph in **Figure 8**.

[1 mark]

Time = _____ s

0 4 . 5 Complete the sentence.

[1 mark]

As the concentration of sodium thiosulfate solution increases, the time taken for the cross to no longer be seen _____.

Turn over ►



0 4 . 6

In one experiment 0.725 g of sulfur is produced in 20 seconds.

Calculate the mean rate of the reaction from 0 to 20 seconds.

Use the equation:

$$\text{mean rate of reaction} = \frac{\text{mass of sulfur produced in grams}}{\text{time in seconds}}$$

[2 marks]

Mean rate of reaction = _____

0 4 . 7

What is the unit for the mean rate of reaction calculated in Question **04.6**?

[1 mark]

Tick (✓) **one** box.

g

g/s

s

s/g



0 4 . 8

The student did the experiment with 0.15 mol/dm^3 sodium thiosulfate solution and repeated the experiment three more times.

Table 2 shows the results.

Table 2

	Test 1	Test 2	Test 3	Test 4
Time in seconds for the cross to no longer be seen	60.5	63.2	82.3	65.7

Calculate the mean time for this reaction.

Do **not** include the anomalous result in your calculation.

Give your answer to 3 significant figures.

[3 marks]

Mean time for the reaction (3 significant figures) = _____ s

14

Turn over for the next question

Turn over ►



0 5

This question is about hydrocarbons.

Figure 9 shows a hydrocarbon.

Figure 9

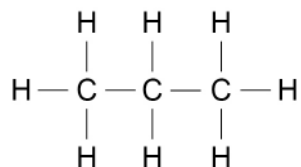

0 5 . 1

Complete the formula for the hydrocarbon shown in **Figure 9**.

[1 mark]

C _____ H _____

0 5 . 2

What is the name of the hydrocarbon in **Figure 9**?

[1 mark]

0 5 . 3

Which homologous series does the hydrocarbon in **Figure 9** belong to?

[1 mark]



0 5 . 4 30 g of another hydrocarbon contains 24 g of carbon.

Which calculation gives the percentage of carbon in the hydrocarbon?

[1 mark]

Tick (✓) **one** box.

$$\frac{24 \times 30}{100}$$

$$\frac{100 \times 30}{24}$$

$$\frac{24 \times 100}{30}$$

$$\frac{24}{30 \times 100}$$

0 5 . 5 **Table 3** shows boiling points of some hydrocarbons.

Table 3

Formula of hydrocarbon	Boiling point in °C
C ₂ H ₆	-89
C ₄ H ₁₀	0
C ₆ H ₁₄	69
C ₈ H ₁₈	125
C ₁₀ H ₂₂	174

Describe how the boiling points change as the number of carbon atoms in the hydrocarbon increases.

[1 mark]

Turn over ►



Hydrocarbons can be cracked.

0 5 . 6 Give **one** condition used to crack hydrocarbons.

[1 mark]

0 5 . 7 Balance the equation for the cracking of C_6H_{14}

[1 mark]

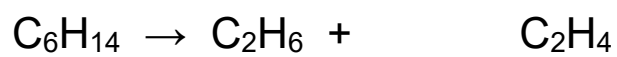

0 5 . 8 Give **one** reason why hydrocarbons are cracked.

[1 mark]



0 5 . 9

Window frames can be manufactured from wood or plastic.

Table 4 shows the results of a life cycle assessment (LCA) for making one wooden and one plastic window frame.

Both window frames are the same size.

Table 4

Table 4 not reproduced here due to third-party copyright restrictions

Give **three** advantages of using wood instead of plastic in the manufacture of window frames.

[3 marks]

Advantage of wood 1 _____

Advantage of wood 2 _____

Advantage of wood 3 _____

11

Turn over for the next question

Turn over ►



0 6

A student investigated the colours in a brown ink using chromatography.

0 6 . 1

Figure 10 shows the apparatus used.

Figure 10

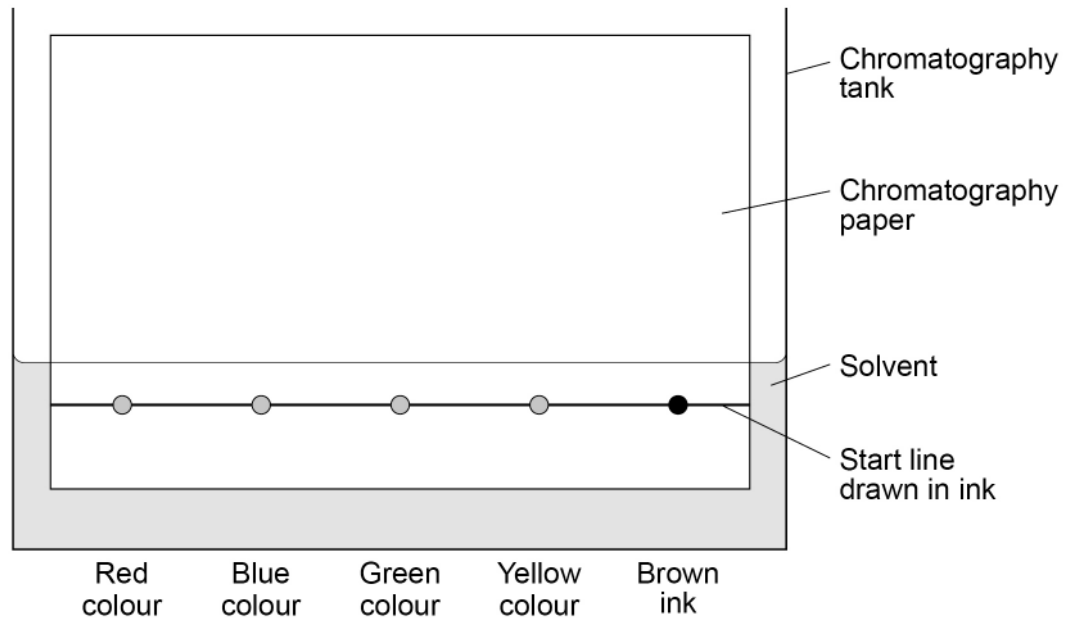

Give **two** errors made by the student.

Describe the problem each error would cause.

[4 marks]

Error 1 _____

Problem 1 _____

Error 2 _____

Problem 2 _____



A different student set up the apparatus correctly.

Figure 11 shows the results.

Figure 11

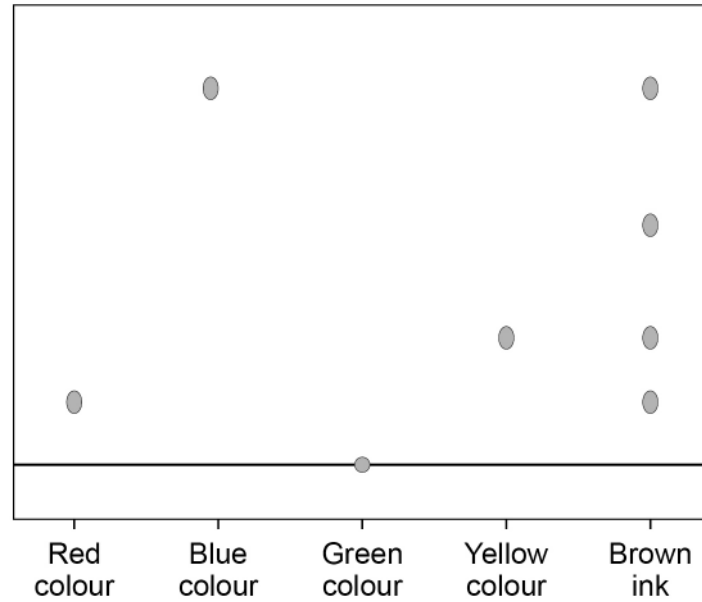

0 6 . 2

Give **two** conclusions the student can make from **Figure 11** about the four colours in the brown ink.

[2 marks]

1 _____

2 _____

Question 6 continues on the next page

Turn over ►



0 6 . 3 Why was the green colour still on the start line at the end of the experiment?

[1 mark]

Tick (✓) **one** box.

The experiment was left for too long.

The green colour was insoluble in the solvent.

The green spot contained too many colours.

The green spot was too small.

0 6 . 4 A student calculated the R_f value of a colour to be 0.24

The colour moved 1.8 cm from the start line.

Calculate the distance the solvent moved.

Use the equation:

$$R_f = \frac{\text{distance moved by colour}}{\text{distance moved by solvent}}$$

[3 marks]

Distance moved by solvent = _____ cm

10



0 7 . 1

Water that is safe to drink is called potable water.

Compare how easily potable water can be obtained from:

- waste water (sewage)
- ground water (fresh water).

[6 marks]

Question 7 continues on the next page

Turn over ►



A scientist produced potable water from 150 cm³ of salty water.

0 7 . 2 Which process can be used to produce potable water from salty water?

[1 mark]

Tick (✓) **one** box.

Distillation

Electrolysis

Filtration

Sterilisation

0 7 . 3 The salty water contains sodium chloride.

The scientist collected 2.40 g of sodium chloride from 150 cm³ of salty water.

Calculate the concentration of sodium chloride in grams per dm³

[3 marks]

Concentration of sodium chloride = _____ g/dm³

10

END OF QUESTIONS



There are no questions printed on this page

*Do not write
outside the
box*

**DO NOT WRITE ON THIS PAGE
ANSWER IN THE SPACES PROVIDED**



There are no questions printed on this page

*Do not write
outside the
box*

**DO NOT WRITE ON THIS PAGE
ANSWER IN THE SPACES PROVIDED**

Copyright information

For confidentiality purposes, all acknowledgements of third-party copyright material are published in a separate booklet. This booklet is published after each live examination series and is available for free download from www.aqa.org.uk.

Permission to reproduce all copyright material has been applied for. In some cases, efforts to contact copyright-holders may have been unsuccessful and AQA will be happy to rectify any omissions of acknowledgements. If you have any queries please contact the Copyright Team.

Copyright © 2022 AQA and its licensors. All rights reserved.

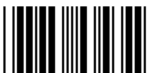

3 2



2 2 6 G 8 4 6 4 / C / 2 F

IB/M/Jun22/8464/C/2F