

Please check the examination details below before entering your candidate information

Candidate surname

Other names

Centre Number

Candidate Number

--	--	--	--	--

--	--	--	--

Pearson Edexcel International GCSE

Time 2 hours

Paper
reference

4MA1/2H

Mathematics A

PAPER 2H

Higher Tier



You must have: Ruler graduated in centimetres and millimetres, protractor, pair of compasses, pen, HB pencil, eraser, calculator. Tracing paper may be used.

Total Marks

Instructions

- Use **black** ink or ball-point pen.
- **Fill in the boxes** at the top of this page with your name, centre number and candidate number.
- Answer **all** questions.
- Without sufficient working, correct answers may be awarded no marks.
- Answer the questions in the spaces provided
– *there may be more space than you need.*
- **Calculators may be used.**
- You must **NOT** write anything on the formulae page.
Anything you write on the formulae page will gain NO credit.

Information

- The total mark for this paper is 100.
- The marks for **each** question are shown in brackets
– *use this as a guide as to how much time to spend on each question.*

Advice

- Read each question carefully before you start to answer it.
- Check your answers if you have time at the end.

Turn over ►

P69203A

©2022 Pearson Education Ltd.

L:1/1/1/1/



Pearson

International GCSE Mathematics

Formulae sheet – Higher Tier

Arithmetic series

Sum to n terms, $S_n = \frac{n}{2} [2a + (n - 1)d]$

Area of trapezium = $\frac{1}{2}(a + b)h$

The quadratic equation

The solutions of $ax^2 + bx + c = 0$ where $a \neq 0$ are given by:

$$x = \frac{-b \pm \sqrt{b^2 - 4ac}}{2a}$$

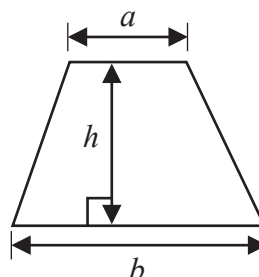

Trigonometry

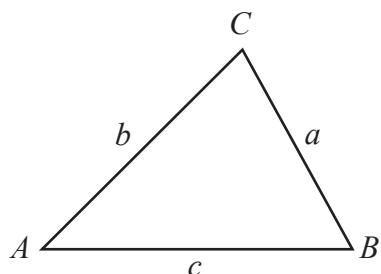

In any triangle ABC

Sine Rule $\frac{a}{\sin A} = \frac{b}{\sin B} = \frac{c}{\sin C}$

Cosine Rule $a^2 = b^2 + c^2 - 2bc \cos A$

Area of triangle = $\frac{1}{2} ab \sin C$

Volume of cone = $\frac{1}{3} \pi r^2 h$

Curved surface area of cone = $\pi r l$

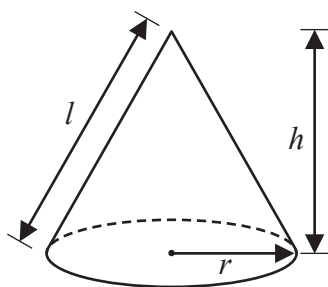

Volume of prism

= area of cross section \times length

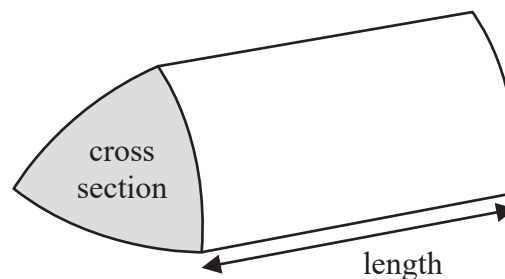

Volume of cylinder = $\pi r^2 h$

Curved surface area of cylinder = $2\pi r h$

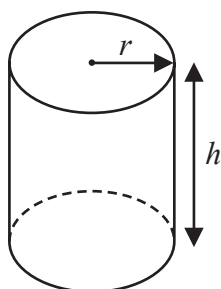

Volume of sphere = $\frac{4}{3} \pi r^3$

Surface area of sphere = $4\pi r^2$

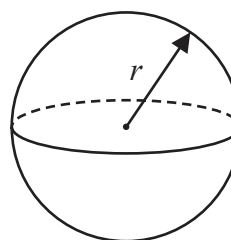

DO NOT WRITE IN THIS AREA

DO NOT WRITE IN THIS AREA

DO NOT WRITE IN THIS AREA



Answer ALL TWENTY SIX questions.

Write your answers in the spaces provided.

You must write down all the stages in your working.

1 (a) Expand and simplify $(y + 4)(2 - y)$

.....
(2)

(b) Factorise fully $15b^5c - 35b^3c^9$

.....
(2)

(Total for Question 1 is 4 marks)

DO NOT WRITE IN THIS AREA

DO NOT WRITE IN THIS AREA

DO NOT WRITE IN THIS AREA



P 6 9 2 0 3 A 0 3 2 8

2 Show that $6\frac{3}{4} \div 2\frac{4}{7} = 2\frac{5}{8}$

DO NOT WRITE IN THIS AREA

DO NOT WRITE IN THIS AREA

DO NOT WRITE IN THIS AREA

(Total for Question 2 is 3 marks)

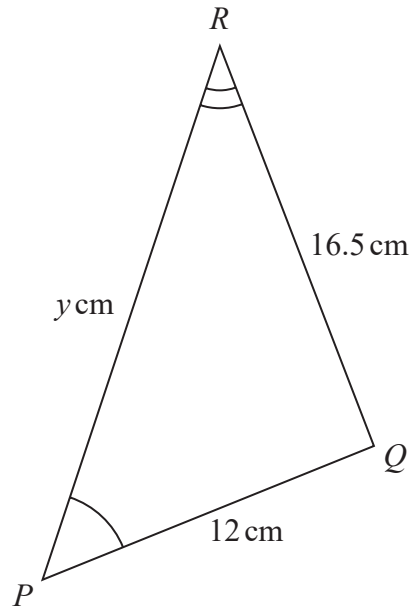
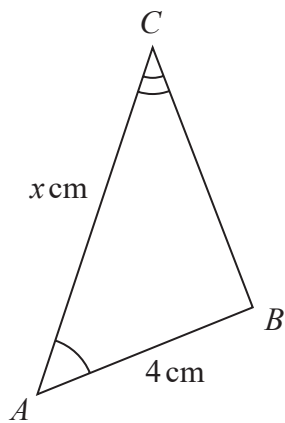

3

Diagram **NOT**
accurately drawnTriangle ABC is similar to triangle PQR

$$AB = 4 \text{ cm} \quad PQ = 12 \text{ cm} \quad RQ = 16.5 \text{ cm} \quad AC = x \text{ cm} \quad PR = y \text{ cm}$$

(a) Calculate the length of BC

..... cm
(1)

(b) Write down an expression for y in terms of x

$y =$
(1)

(Total for Question 3 is 3 marks)



4 Each side of a regular octagon has a length of 18 mm, correct to the nearest 0.5 mm

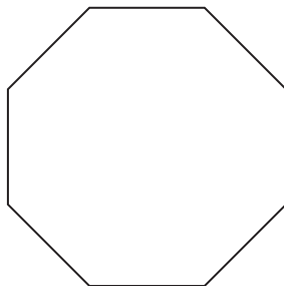

Diagram **NOT** accurately drawn

DO NOT WRITE IN THIS AREA

DO NOT WRITE IN THIS AREA

DO NOT WRITE IN THIS AREA

(a) Write down the lower bound of the length of each side of the octagon.

..... mm
(1)

(b) Write down the upper bound of the length of each side of the octagon.

..... mm
(1)

(Total for Question 4 is 2 marks)



5 The scale diagram shows the position on a map of a house, A

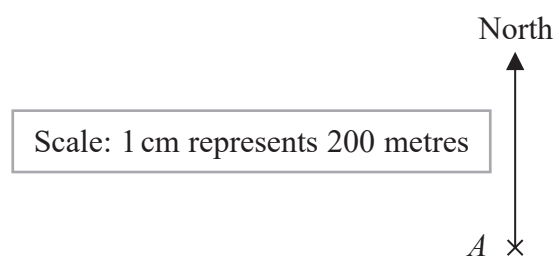

House C is on a bearing of 110° from A
The distance from A to C is 700 m

- (a) Mark the position of C on the diagram with a cross (×)
Label your cross C

(3)

- (b) Write the scale of the map in the form $1:n$

1 :
(1)

(Total for Question 5 is 4 marks)



6 A bag contains only pink sweets, white sweets, green sweets and red sweets.

The table gives each of the probabilities that, when a sweet is taken at random from the bag, the sweet will be green or the sweet will be red.

Sweet	pink	white	green	red
Probability			0.2	0.35

The ratio

number of pink sweets : number of white sweets = 2 : 1

There are 28 red sweets in the bag.

Work out the number of white sweets in the bag.

.....
(Total for Question 6 is 5 marks)



- 7 Find the lowest common multiple (LCM) of 28, 42 and 63
Show your working clearly.

DO NOT WRITE IN THIS AREA

DO NOT WRITE IN THIS AREA

DO NOT WRITE IN THIS AREA

.....
(Total for Question 7 is 3 marks)



- 8 The table gives information about the average house price in England in 2018 and in 2019

Year	2017	2018	2019
Average house price (£)		228 314	231 776

- (a) Work out the percentage increase in the average house price from 2018 to 2019
Give your answer correct to one decimal place.

..... %
(2)

The average house price in 2019 was 7.7% greater than the average house price in 2017

- (b) Work out the average house price in 2017
Give your answer correct to 3 significant figures.

£
(3)

(Total for Question 8 is 5 marks)

DO NOT WRITE IN THIS AREA

DO NOT WRITE IN THIS AREA

DO NOT WRITE IN THIS AREA



DO NOT WRITE IN THIS AREA

DO NOT WRITE IN THIS AREA

DO NOT WRITE IN THIS AREA

9 The frequency table gives information about the number of points scored by a player.

Number of points	Frequency
0	13
1	17
2	8
3	x
4	11

The mean number of points scored is 2

Work out the value of x

$x = \dots\dots\dots$

(Total for Question 9 is 4 marks)



P 6 9 2 0 3 A 0 1 1 2 8

10 Solve the simultaneous equations

$$3x + 5y = 3.1$$

$$6x + 3y = 3.75$$

Show clear algebraic working.

$$x = \dots\dots\dots$$

$$y = \dots\dots\dots$$

(Total for Question 10 is 3 marks)

DO NOT WRITE IN THIS AREA

DO NOT WRITE IN THIS AREA

DO NOT WRITE IN THIS AREA



DO NOT WRITE IN THIS AREA

DO NOT WRITE IN THIS AREA

DO NOT WRITE IN THIS AREA

11 The diagram shows a regular 10-sided polygon, $ABCDEFGHIJ$

Diagram **NOT** accurately drawn

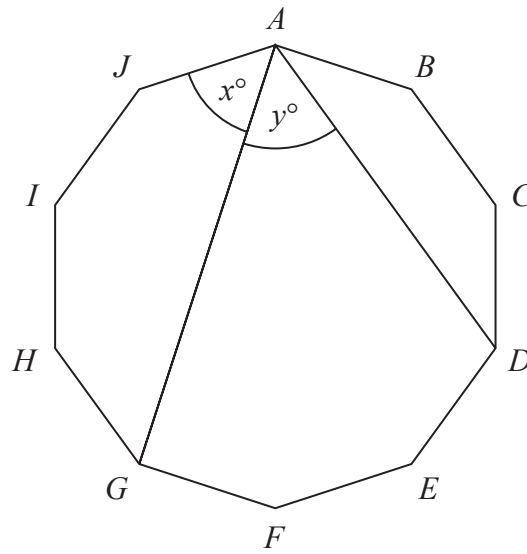

Show that $x = y$

(Total for Question 11 is 4 marks)



P 6 9 2 0 3 A 0 1 3 2 8

12 $a = 6 \times 10^{40}$

Work out the value of a^3

Give your answer in standard form.

.....
(Total for Question 12 is 3 marks)

DO NOT WRITE IN THIS AREA

DO NOT WRITE IN THIS AREA

DO NOT WRITE IN THIS AREA



DO NOT WRITE IN THIS AREA

DO NOT WRITE IN THIS AREA

DO NOT WRITE IN THIS AREA

- 13 The shaded region in the diagram is bounded by three lines.
The equation of one of the lines is given.

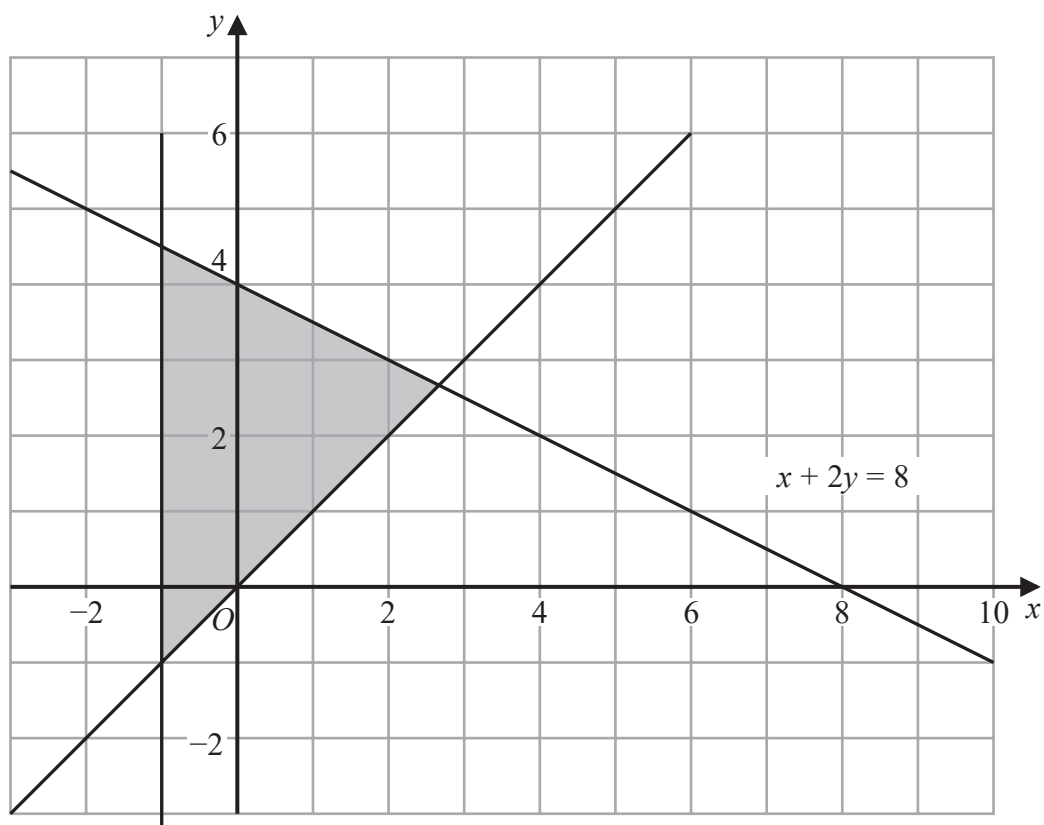

Write down three inequalities that define the shaded region.

.....

.....

.....

(Total for Question 13 is 3 marks)



P 6 9 2 0 3 A 0 1 5 2 8

14 A zip wire is shown as the dashed line AC in the diagram.

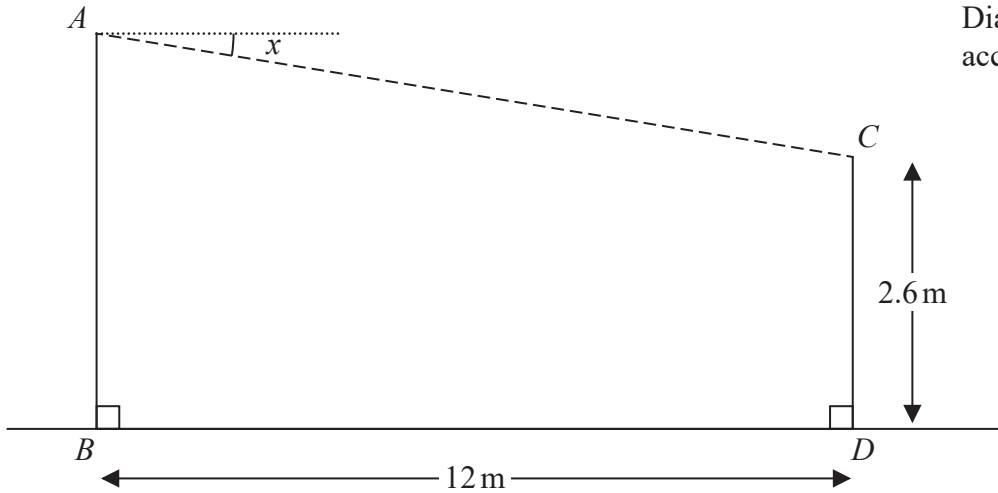

Diagram NOT accurately drawn

The zip wire is supported by two vertical posts AB and CD standing on horizontal ground.

$$CD = 2.6\text{ m} \quad BD = 12\text{ m}$$

The zip wire makes an angle x with the horizontal, as shown in the diagram. The design of the zip wire requires the angle x to be at least 5°

Work out the least possible height of the post AB
Give your answer correct to 3 significant figures.

..... m

(Total for Question 14 is 3 marks)

DO NOT WRITE IN THIS AREA

DO NOT WRITE IN THIS AREA

DO NOT WRITE IN THIS AREA



DO NOT WRITE IN THIS AREA

DO NOT WRITE IN THIS AREA

DO NOT WRITE IN THIS AREA

15 Diyar recorded the distance, in kilometres, that he cycled each day for 11 days.
Here are his results.

8 10 12 13 5 23 21 7 5 16 14

Find the interquartile range of his results.

..... km

(Total for Question 15 is 3 marks)



16 D, E, F and G are points on a circle, centre O

Diagram **NOT**
accurately drawn

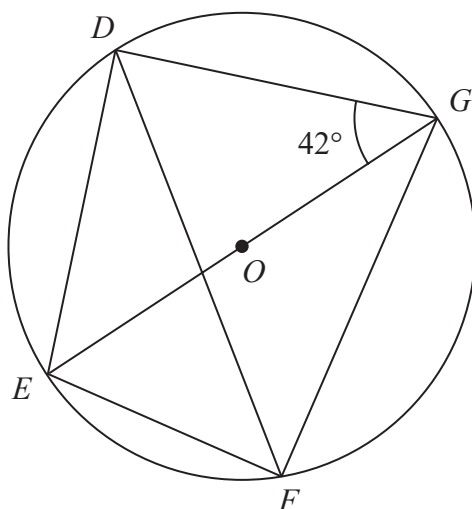

EOG is a diameter of the circle.

Angle $EGD = 42^\circ$

Calculate the size of angle DFG

Give a reason for each stage of your working.

Angle $DFG = \dots\dots\dots^\circ$

(Total for Question 16 is 4 marks)

DO NOT WRITE IN THIS AREA

DO NOT WRITE IN THIS AREA

DO NOT WRITE IN THIS AREA



17 Show that $\frac{\sqrt{12}}{\sqrt{3} + 2}$

can be written in the form $a + \sqrt{b}$ where a and b are integers.

(Total for Question 17 is 3 marks)



DO NOT WRITE IN THIS AREA

DO NOT WRITE IN THIS AREA

DO NOT WRITE IN THIS AREA

18 Prove that when the sum of the squares of any two consecutive odd numbers is divided by 8, the remainder is always 2
Show clear algebraic working.

DO NOT WRITE IN THIS AREA

DO NOT WRITE IN THIS AREA

(Total for Question 18 is 3 marks)

DO NOT WRITE IN THIS AREA



19

Diagram NOT accurately drawn

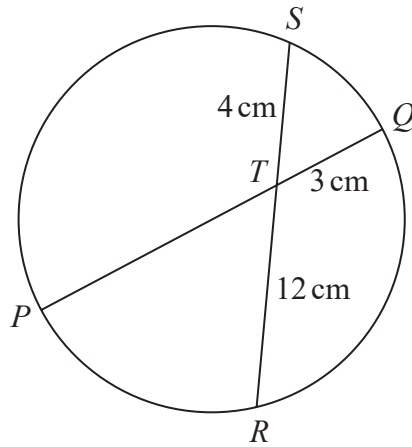

PTQ is a diameter of a circle.
 RTS is a chord of the circle.

$TQ = 3\text{ cm}$ $ST = 4\text{ cm}$ $TR = 12\text{ cm}$

Calculate the radius of the circle.

..... cm

(Total for Question 19 is 3 marks)

DO NOT WRITE IN THIS AREA

DO NOT WRITE IN THIS AREA

DO NOT WRITE IN THIS AREA



P 6 9 2 0 3 A 0 2 1 2 8

20 The histogram gives information about the heights, h cm, of some tomato plants.

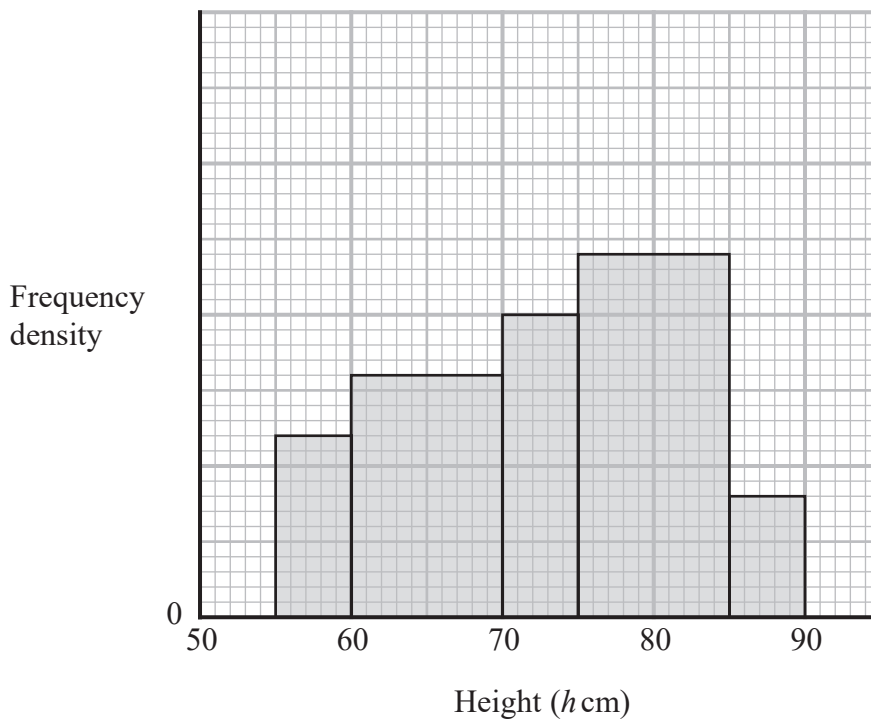

There are 12 tomato plants for which $75 < h \leq 85$
 One of the tomato plants is selected at random.

Find an estimate for the probability that this tomato plant has a height greater than 82.5 cm

(Total for Question 20 is 4 marks)

DO NOT WRITE IN THIS AREA

DO NOT WRITE IN THIS AREA

DO NOT WRITE IN THIS AREA



21 Part of the graph of $y = 2x^2 - 4x - 1$ is shown on the grid.

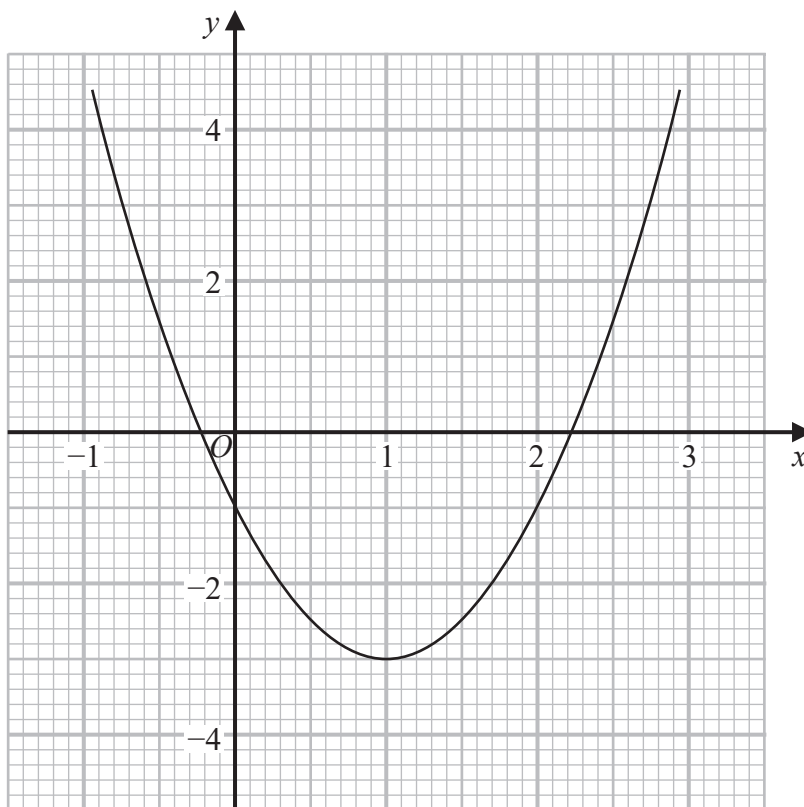

- (a) Use the graph to find estimates for the solutions of the equation $2x^2 - 4x - 1 = 0$
Give your solutions correct to one decimal place.

.....
(2)

- (b) By drawing a suitable straight line on the grid, find estimates for the solutions of the equation $x^2 - x - 1 = 0$
Show your working clearly.
Give your solutions correct to one decimal place.

.....
(3)

(Total for Question 21 is 5 marks)

DO NOT WRITE IN THIS AREA

DO NOT WRITE IN THIS AREA

DO NOT WRITE IN THIS AREA



22 Here is a rectangle.

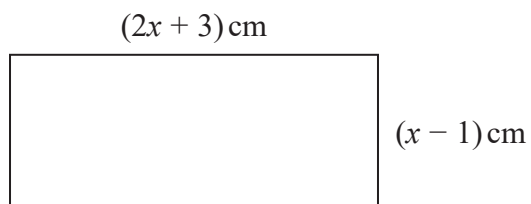

Diagram **NOT**
accurately drawn

Given that the area of the rectangle is less than 75 cm^2

find the range of possible values of x

DO NOT WRITE IN THIS AREA

DO NOT WRITE IN THIS AREA

DO NOT WRITE IN THIS AREA

.....
(Total for Question 22 is 5 marks)



DO NOT WRITE IN THIS AREA

DO NOT WRITE IN THIS AREA

DO NOT WRITE IN THIS AREA

23 The diagram shows triangle PQR

Diagram **NOT** accurately drawn

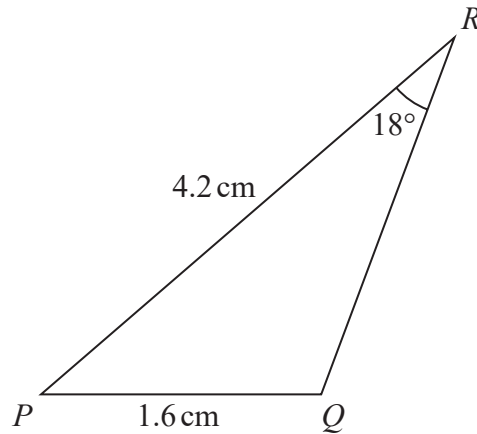

$PQ = 1.6 \text{ cm}$ $PR = 4.2 \text{ cm}$ Angle $PRQ = 18^\circ$

Given that angle PQR is obtuse,

work out the area of triangle PQR

Give your answer correct to 3 significant figures.

..... cm^2

(Total for Question 23 is 6 marks)



P 6 9 2 0 3 A 0 2 5 2 8

24 A particle P moves along a straight line that passes through the fixed point O

The displacement, x metres, of P from O at time t seconds, where $t \geq 0$, is given by

$$x = 4t^3 - 27t + 8$$

The direction of motion of P reverses when P is at the point A on the line.

The acceleration of P at the instant when P is at A is $a \text{ m/s}^2$

Find the value of a

$a = \dots\dots\dots$

(Total for Question 24 is 5 marks)

DO NOT WRITE IN THIS AREA

DO NOT WRITE IN THIS AREA

DO NOT WRITE IN THIS AREA



DO NOT WRITE IN THIS AREA

DO NOT WRITE IN THIS AREA

DO NOT WRITE IN THIS AREA

25 The function g is defined as

$$g: x \mapsto 5 + 6x - x^2 \quad \text{with domain } \{x: x \geq 3\}$$

(a) Express the inverse function g^{-1} in the form $g^{-1}: x \mapsto \dots$

$$g^{-1}: x \mapsto \dots \dots \dots \quad (4)$$

(b) State the domain of g^{-1}

$$\dots \dots \dots \quad (1)$$

(Total for Question 25 is 5 marks)



P 6 9 2 0 3 A 0 2 7 2 8

26 An arithmetic series has first term a and common difference d , where d is a prime number.

The sum of the first n terms of the series is S_n and

$$S_m = 39$$

$$S_{2m} = 320$$

Find the value of d and the value of m
Show clear algebraic working.

$$d = \dots\dots\dots$$

$$m = \dots\dots\dots$$

(Total for Question 26 is 5 marks)

TOTAL FOR PAPER IS 100 MARKS

DO NOT WRITE IN THIS AREA

DO NOT WRITE IN THIS AREA

DO NOT WRITE IN THIS AREA

