

**Friday 27 May 2022 – Morning**

**GCSE (9–1) Combined Science  
(Chemistry) A (Gateway Science)**

**J250/09 Paper 9 (Higher Tier)**

**Time allowed: 1 hour 10 minutes**

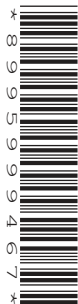

**You must have:**

- a ruler (cm/mm)
- the Data Sheet for GCSE (9–1) Combined Science (Chemistry) A (inside this document)

**You can use:**

- a scientific or graphical calculator
- an HB pencil



Please write clearly in black ink. **Do not write in the barcodes.**

Centre number

--	--	--	--	--

Candidate number

--	--	--	--

First name(s)

---

Last name

---

**INSTRUCTIONS**

- Use black ink. You can use an HB pencil, but only for graphs and diagrams.
- Write your answer to each question in the space provided. If you need extra space use the lined pages at the end of this booklet. The question numbers must be clearly shown.
- Answer **all** the questions.
- Where appropriate, your answer should be supported with working. Marks might be given for using a correct method, even if your answer is wrong.

**INFORMATION**

- The total mark for this paper is **60**.
- The marks for each question are shown in brackets [ ].
- Quality of extended response will be assessed in questions marked with an asterisk (\*).
- This document has **20** pages.

**ADVICE**

- Read each question carefully before you start your answer.

**2**  
**SECTION A**

Answer **all** the questions.

You should spend a maximum of 20 minutes on this section.

**Write your answer to each question in the box provided.**

- 1** A molecule of glucose has the molecular formula  $C_6H_{12}O_6$ .

What is the **empirical formula** of glucose?

- A** CHO
- B**  $CH_2O$
- C**  $C_6H_{12}O_6$
- D**  $(CO)_6H_{12}$

Your answer

[1]

- 2** The equation shows the reaction between carbon dioxide,  $CO_2$ , and hydrogen,  $H_2$ .

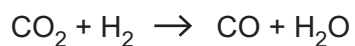

What has been **reduced** in this reaction?

- A** CO
- B**  $CO_2$
- C**  $H_2$
- D**  $H_2O$

Your answer

[1]

3 Which statement describes the **isotopes** of an element?

- A Atoms that have different numbers of protons but the same number of electrons.
- B Atoms that have different numbers of protons but the same number of neutrons.
- C Atoms that have the same number of protons but different numbers of electrons.
- D Atoms that have the same number of protons but different numbers of neutrons.

Your answer

[1]

4 Which substance is an example of a **formulation**?

- A A macromolecule
- B A metal
- C An alloy
- D An ionic compound

Your answer

[1]

- 5 The diagram shows a chromatogram produced by paper chromatography.

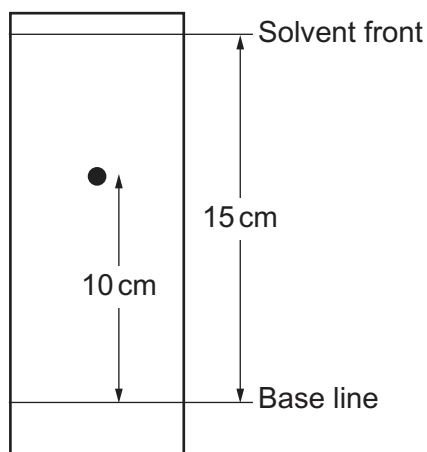

What is the  $R_f$  value?

- A -10
- B -5
- C 0.67
- D 1.5

Your answer

[1]

- 6 The table shows some information about four different acids.

Acid	Number of particles per $\text{cm}^3$ of acid solution	Degree of ionisation (%)
A	high	1
B	low	1
C	high	100
D	low	100

Which acid is a **dilute** solution of a **strong** acid?

Your answer

[1]

- 7 The ionic equation shows the reaction of chlorine,  $\text{Cl}_2$ , with sodium bromide,  $\text{NaBr}$ .

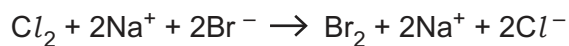

What is the **simplest** ionic equation for this reaction?

- A  $\text{Cl}_2 + 2\text{NaBr} \rightarrow \text{Br}_2 + 2\text{NaCl}$   
 B  $\text{Cl}_2 + \text{Na}^+ + \text{Br}^- \rightarrow \text{Br}_2 + \text{Na}^+ + \text{Cl}^-$   
 C  $\text{Cl}_2 + \text{Br}^- \rightarrow \text{Br}_2 + \text{Cl}^-$   
 D  $\text{Cl}_2 + 2\text{Br}^- \rightarrow \text{Br}_2 + 2\text{Cl}^-$

Your answer

[1]

- 8 The diagram shows the reaction of hydrogen,  $\text{H}_2$ , and oxygen,  $\text{O}_2$ , to make water,  $\text{H}_2\text{O}$ .

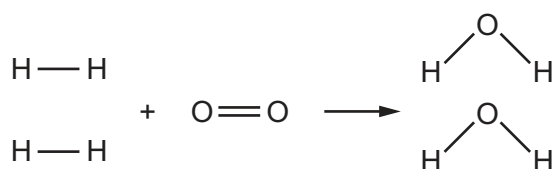

The energy required to break all the  $\text{H}-\text{H}$  and  $\text{O}=\text{O}$  bonds is 1368 kJ/mol.  
 The energy change for the reaction is -484 kJ/mol.

What is the bond energy for the **O-H** bond?

- A 463 kJ/mol  
 B 884 kJ/mol  
 C 926 kJ/mol  
 D 1852 kJ/mol

Your answer

[1]

9 A solution has a pH of 3.

The solution is diluted with water by a factor of 1000.

What is the pH of the solution **after** dilution?

A 2

B 4

C 5

D 6

Your answer

[1]

10 What is the definition of the **mole**?

A One mole contains 1 g of atoms.

B One mole contains  $6.022 \times 10^{23}$  particles.

C One mole is equal to the relative atomic mass of an element.

D One mole is the number of atoms contained in one molecule.

Your answer

[1]

**7**  
**BLANK PAGE**

**PLEASE DO NOT WRITE ON THIS PAGE**

8  
SECTION B

Answer **all** the questions.

11 Fullerenes are allotropes of carbon that have many uses.

Fig. 11.1 shows a molecule of a fullerene.

Fig. 11.1

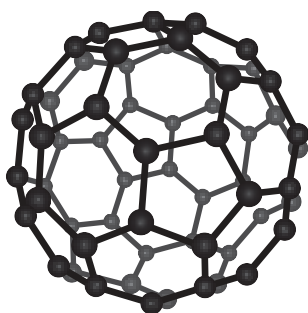

(a) (i) Which group of allotropes contain this fullerene?

Tick **one** (✓) box.

Inorganic

Organic

Physical

[1]

(ii) What is the approximate size of a molecule of this fullerene?

Tick **one** (✓) box.

$1 \times 10^{-15} \text{ m}$

$1 \times 10^{-10} \text{ m}$

$1 \times 10^{-5} \text{ m}$

[1]



(b) The carbon atoms in fullerenes are joined by covalent bonds.

(i) Explain how two atoms of carbon form a covalent bond.

.....

.....

.....

..... [2]

(ii) How many covalent bonds does one atom of carbon form in a molecule of fullerene, as shown in **Fig. 11.1**?

..... [1]

(c) The model used to show the molecule of fullerene in **Fig. 11.1** has limitations.

The table shows some statements about the model.

Which statements about this model are **true**, and which are **false**?

Tick **one** (✓) box in each row.

	<b>True</b>	<b>False</b>
It shows the length of the covalent bonds.		
It shows the size of the carbon atoms.		
It shows the three-dimensional shape of the molecule.		

[2]

(d) Fullerenes can be used as lubricants. Lubricants reduce the friction between moving parts.

Fig. 11.2 shows a lubricant being sprayed onto the chain of a motorbike.

Fig. 11.2

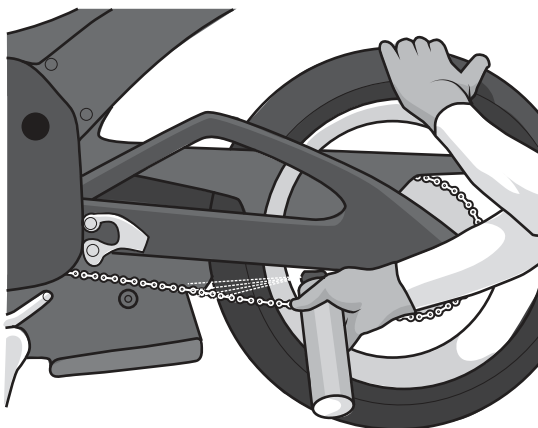

(i) Explain why fullerenes can be used as lubricants.

Use ideas about the structure and bonding of the fullerene shown in Fig. 11.1 in your answer.

.....

.....

.....

..... [2]

(ii) A lubricant may need to be used at high temperatures.

Explain why fullerenes can be used at high temperatures.

Use ideas about the structure and bonding of the fullerene shown in Fig. 11.1 in your answer.

.....

.....

.....

.....

.....

..... [3]

11  
BLANK PAGE

PLEASE DO NOT WRITE ON THIS PAGE

12 Potassium chloride,  $KCl$ , is an ionic compound.

It is made from potassium ions,  $K^+$ , and chloride ions,  $Cl^-$ .

(a) Explain why potassium is found in Group 1 of the Periodic Table.

Use ideas about the arrangement of electrons in an atom of potassium.

.....  
 ..... [1]

(b) Explain how an atom of potassium reacts with an atom of chlorine to make potassium chloride.

.....  
 .....  
 ..... [2]

(c) A student electrolyses potassium chloride.

The diagram shows the equipment they use.

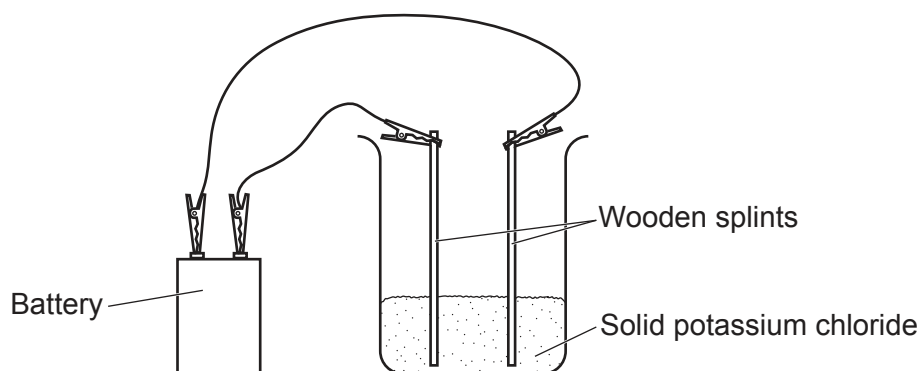

The student's experiment does **not** work.

Describe and explain **two** ways the student could change the experiment to make it work.

1 .....

.....

.....

2 .....

.....

.....

[4]

(d) In the successful electrolysis of potassium chloride, potassium is made at the cathode.

Explain how potassium atoms are made from potassium ions.

.....

.....

.....

.....

..... [3]

**13\*** Hydrogen can form compounds with the Group 7 elements. These compounds are simple covalent molecules.

For example,

hydrogen + chlorine  $\rightarrow$  hydrogen chloride

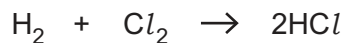

When simple covalent molecules are heated, they thermally decompose back into their elements.

For example,

hydrogen chloride  $\rightarrow$  hydrogen + chlorine



**Tables 13.1** and **13.2** show information about the compounds formed from hydrogen and some Group 7 elements.

**Table 13.1**

Compound	Structure of molecule	Boiling point (°C)	Temperature needed for thermal decomposition (°C)
hydrogen chloride	H-Cl	-85	over 1500
hydrogen bromide	H-Br	-67	over 1000
hydrogen iodide	H-I	-35	over 200

**Table 13.2**

Compound	Structure of molecule	Size of molecule (pm)	Strength of covalent bond (kJ/mol)
hydrogen chloride	H-Cl	127	431
hydrogen bromide	H-Br	141	366
hydrogen iodide	H-I	161	299



14 Calcium is a metal found in Group 2 of the Periodic Table.

(a) Draw the arrangement of electrons in an atom of calcium.

[1]

(b) Calcium is a metal which can conduct electricity.

Describe the structure and bonding in a metal **and** explain why metals can conduct electricity.

You can include a diagram in your answer.

.....

.....

.....

.....

.....

.....

.....

.....

.....

.....

[4]



(c) Calcium reacts with water to form a solution of calcium hydroxide,  $\text{Ca}(\text{OH})_2$ , and hydrogen.

(i) Write the **balanced symbol** equation for the reaction of calcium with water.

Include **state symbols** in your equation.

..... [3]

(ii) A solution of calcium hydroxide is also called **limewater**.

Name the gas limewater is used as a test for.

..... [1]

(d)  $250 \text{ cm}^3$  of a solution contains 1.88 g of calcium hydroxide,  $\text{Ca}(\text{OH})_2$ .

(i) Calculate the **number of moles** in 1.88 g of calcium hydroxide.

Give your answer to **2** significant figures.

Relative atomic mass ( $A_r$ ):    H = 1.0    O = 16.0    Ca = 40.1

Number of moles of calcium hydroxide = ..... [3]

(ii) Use your answer to part (d)(i) to calculate the concentration of calcium hydroxide in the solution formed.

Give your answer in  $\text{mol/dm}^3$ .

Concentration of solution = .....  $\text{mol/dm}^3$  [2]  
**Turn over**

(e) A student adds an excess of dilute hydrochloric acid,  $\text{HCl}$ , to a solution of calcium hydroxide,  $\text{Ca(OH)}_2$ .

(i) Write the **balanced ionic** equation for the reaction of dilute hydrochloric acid and a solution of calcium hydroxide.

..... [1]

(ii) Describe and explain how the pH of the solution of calcium hydroxide changes as the dilute hydrochloric acid is added until it is in excess.

.....  
.....  
.....  
.....  
.....  
.....  
..... [3]

15 Colour changes can be used to show that oxidation and reduction happen in chemical reactions.

The diagram shows the reaction between an acidic solution of vanadium(IV) oxide and zinc.

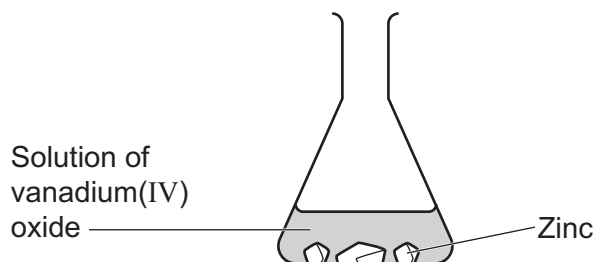

- As the reaction happens the colour of the solution turns from **blue** to **green**.

The balanced half equation shows the reaction of vanadium(IV) oxide.

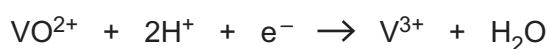

- (a) A student thinks that the half equation shows that **reduction** has taken place.

Describe **two** ways in which the half equation shows the student is **correct**.

1 .....

.....

2 .....

.....

[2]

- (b) This half equation shows the reaction of the zinc.



Complete the **half equation** for the reaction.

[1]

- (c) The student removes the zinc from the green solution by filtration. When they add some nitric acid to this solution it turns back from **green to blue**.

What is the role of the dilute nitric acid in this reaction?

Tick **one** (✓) box.

A base

A reducing agent

An oxidising agent

[1]

**END OF QUESTION PAPER**

**ADDITIONAL ANSWER SPACE**

If additional space is required, you should use the following lined page(s). The question number(s) must be clearly shown in the margin(s).

A large rectangular area with a solid vertical line on the left side and horizontal dotted lines across the rest of the page, providing space for writing answers.



**Copyright Information**

OCR is committed to seeking permission to reproduce all third-party content that it uses in its assessment materials. OCR has attempted to identify and contact all copyright holders whose work is used in this paper. To avoid the issue of disclosure of answer-related information to candidates, all copyright acknowledgements are reproduced in the OCR Copyright Acknowledgements Booklet. This is produced for each series of examinations and is freely available to download from our public website ([www.ocr.org.uk](http://www.ocr.org.uk)) after the live examination series.

If OCR has unwittingly failed to correctly acknowledge or clear any third-party content in this assessment material, OCR will be happy to correct its mistake at the earliest possible opportunity.

For queries or further information please contact The OCR Copyright Team, The Triangle Building, Shaftesbury Road, Cambridge CB2 8EA.

OCR is part of Cambridge University Press & Assessment, which is itself a department of the University of Cambridge.