

Wednesday 22 May 2019 – Afternoon

GCSE (9–1) in Combined Science B (Twenty First Century Science)

J260/07 Physics (Higher Tier)

Time allowed: 1 hour 45 minutes

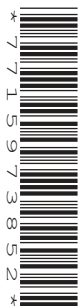

You must have:

- the Data Sheet (for GCSE Combined Science B (inserted))
- a ruler (cm/mm)

You may use:

- a scientific or graphical calculator
- an HB pencil



Please write clearly in black ink. **Do not write in the barcodes.**

Centre number

--	--	--	--	--

Candidate number

--	--	--	--

First name(s)

Last name

INSTRUCTIONS

- The Data Sheet will be found inside this document.
- Use black ink. You may use an HB pencil for graphs and diagrams.
- Answer **all** the questions.
- Where appropriate, your answers should be supported with working. Marks may be given for a correct method even if the answer is incorrect.
- Write your answer to each question in the space provided. If additional space is required, use the lined page(s) at the end of this booklet. The question number(s) must be clearly shown.

INFORMATION

- The total mark for this paper is **95**.
- The marks for each question are shown in brackets [].
- Quality of extended responses will be assessed in the question marked with an asterisk (*).
- This document consists of **24** pages.

2
BLANK PAGE

PLEASE DO NOT WRITE ON THIS PAGE

Answer **all** the questions.

- 1 Electrical power is transferred from power stations to homes by the National Grid, as shown in the diagram.

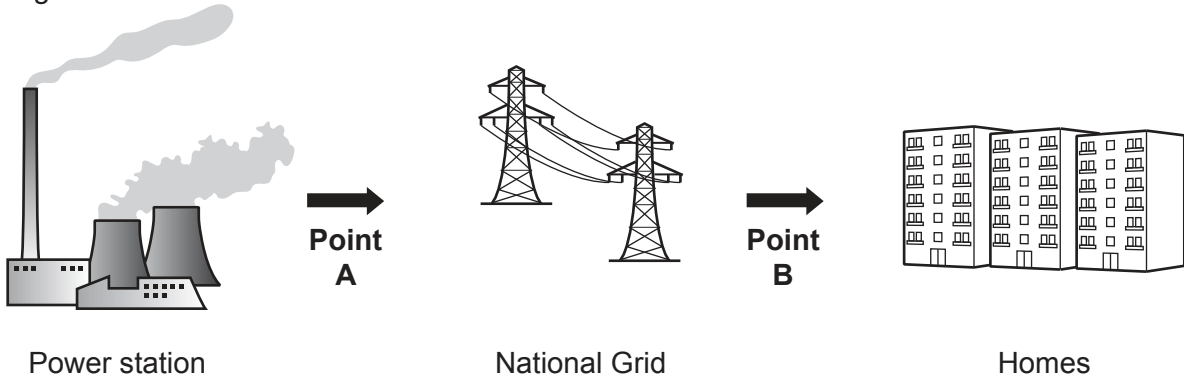

(a) In the National Grid, what is the name of the devices that change the voltage?
 [1]

(b) Complete the sentences about the diagram. Use words from the list.
 You may use each word once, more than once, or not at all.

decreased increased unchanged

At **Point A**, the potential difference (voltage) is

At **Point B**, the potential difference (voltage) is [1]

(c) Appliances can be connected to the mains electricity supply in homes using 3-pin plugs.

(i) What is the potential difference (voltage) of the mains electricity in a home?

Potential difference (voltage) = V [1]

(ii) Amaya thinks of a hazard with using mains electricity.

Amaya
 It is dangerous if there is a connection between the live wire and an earthed object.



Explain why Amaya is correct.

.....

.....

.....

..... [2]

2 Alex is frying potatoes in oil. Ben is boiling potatoes in water.

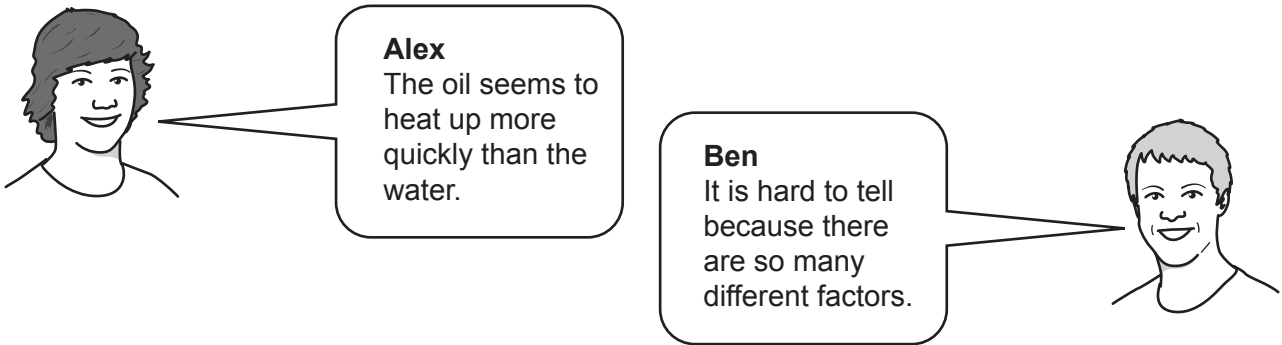

Their teacher suggests they compare the specific heat capacities of oil and water.

Alex and Ben set up the apparatus shown in this diagram to measure the specific heat capacity of the oil.

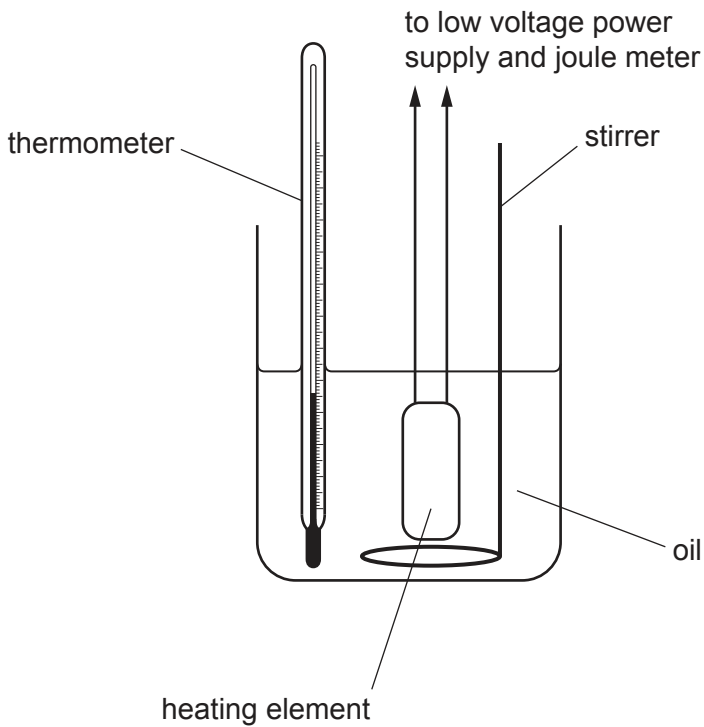

(a) Explain how they can safely use the apparatus, to take measurements, and to determine the specific heat capacity of the oil.

.....

.....

.....

.....

.....

.....

[3]

(b) Alex and Ben repeat their experiment 3 times. Their results are shown in **Table 2.1**.

Specific heat capacity of oil (kJ/kg °C)	Experiment 1	Experiment 2	Experiment 3
	1.94	2.23	1.98

Table 2.1

Calculate the mean specific heat capacity of the oil, using all the data in **Table 2.1**.

Mean specific heat capacity = kJ/kg °C [2]

(c) **Table 2.2** shows accurate values for the specific heat capacities of the oil and water.

Liquid	Specific heat capacity (kJ/kg °C)
oil	1.7
water	4.2

Table 2.2

Compare the accurate value for the oil with Alex and Ben's calculated value in (b).

Suggest a reason for the difference, and suggest how they could improve their experiment to get a more accurate result.

.....

.....

.....

.....

.....

.....

..... [3]

3* These pie charts show the energy resources used to generate electricity in the UK in **2013**, **2014**, and **2015**.

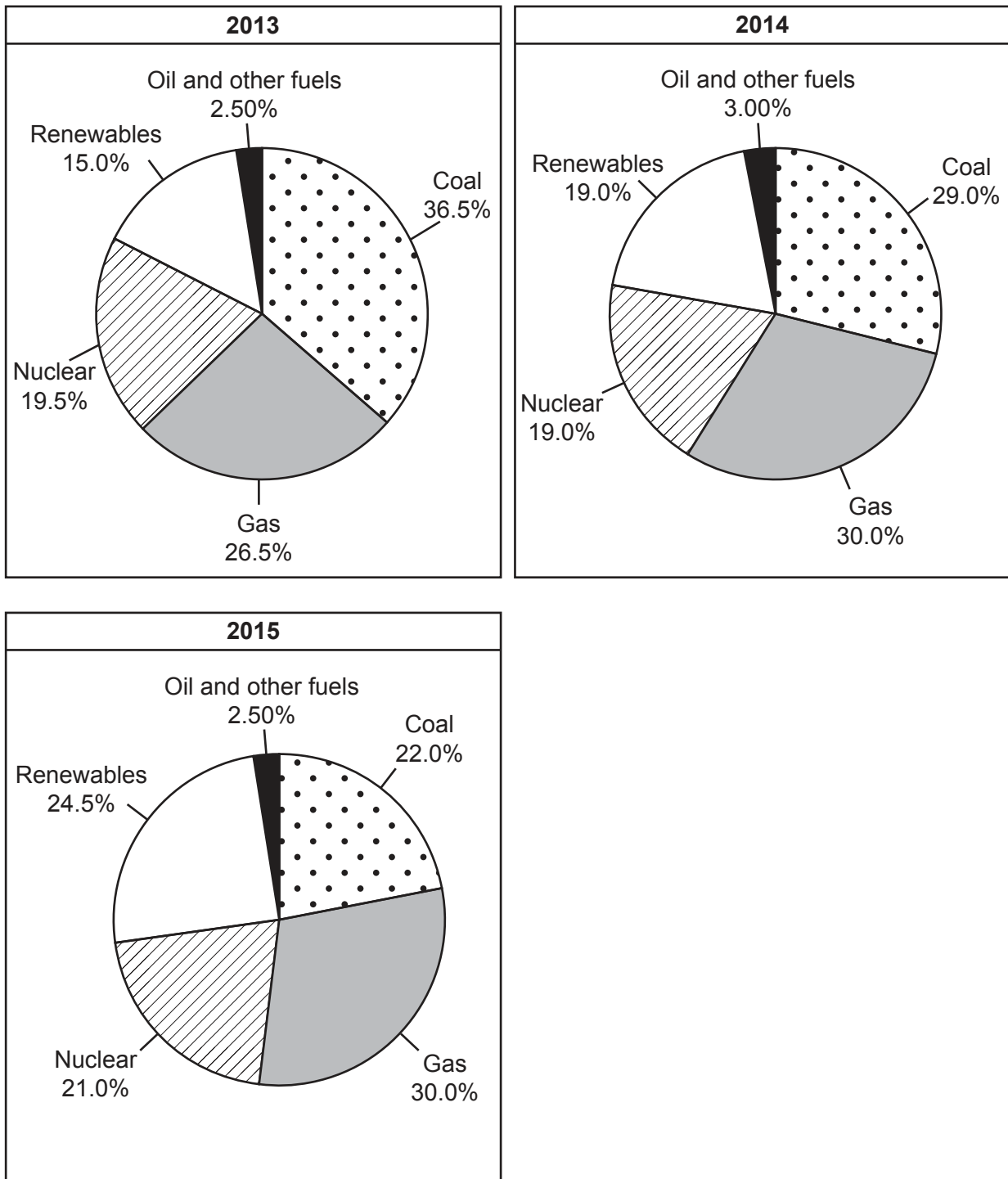

Describe in detail how the energy resources used to generate electricity in the UK have changed from 2013 to 2015.

Suggest reasons for these trends.

Use information from the pie charts to support your answer.

.....
.....
.....
.....
.....
.....
.....
.....
.....
.....
.....
.....
.....
.....
.....
.....
.....
.....
.....
.....
.....
..... [6]

4 The diagram below shows a game that uses magnets.

When the stick is moved near the boat, the boat moves towards it.

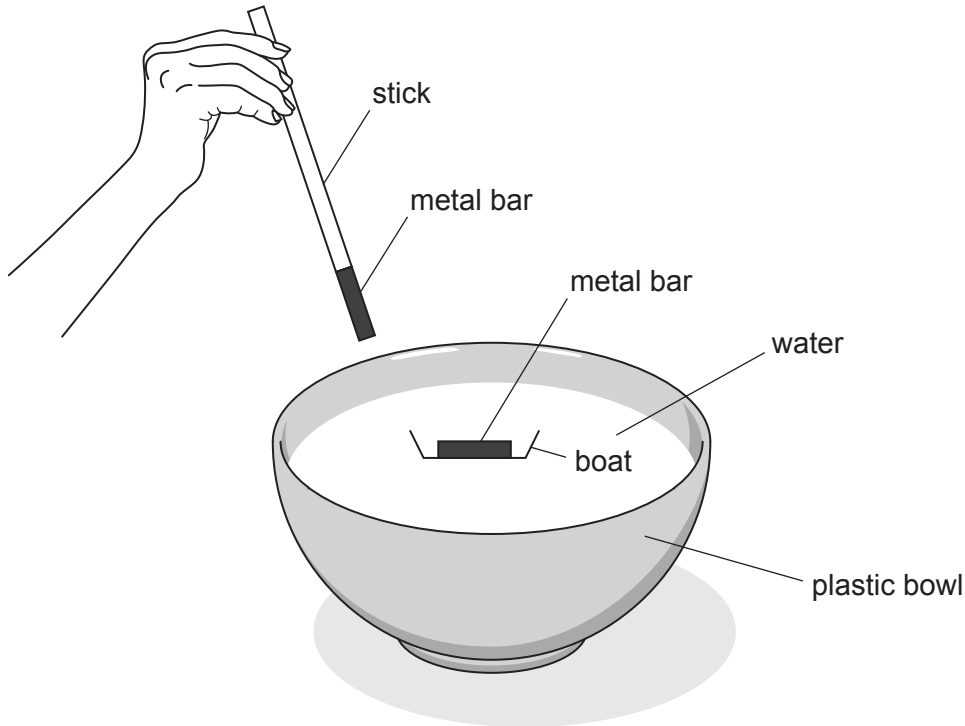

Two students are discussing why the boat moves towards the stick.

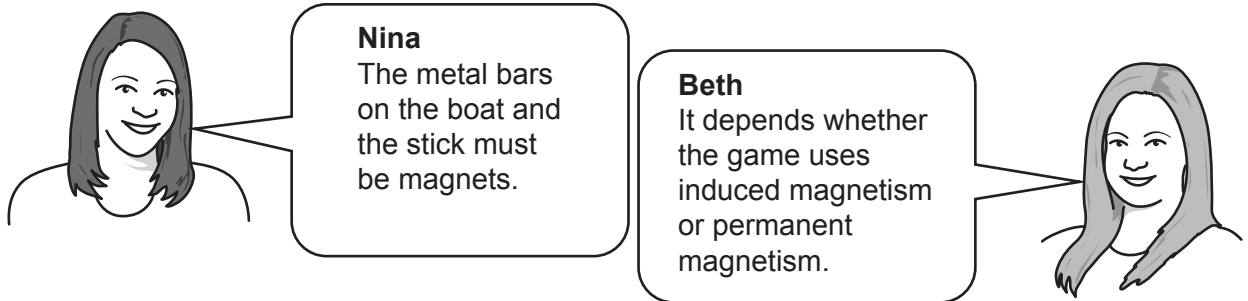

(a) (i) Describe the difference between a permanent magnet and an induced magnet.

.....

 [1]

(ii) Describe what happens if the poles of two permanent magnets are brought close together:

When unlike poles are brought close together, they

When like poles are brought close together, they

[1]

- (iii) Describe how the strength and direction of the magnetic field change around a bar magnet.

Add to the diagram to help you answer the question.



.....
..... [2]

- (b) Beth takes the stick away. Nina points the boat in a different direction. The boat slowly rotates to point to the left (←).

Nina then points the boat in other different directions. Each time, it slowly rotates until it points to the left (←).

What conclusions can you draw from this behaviour?

.....
.....
..... [2]

- (c) Beth has a magnetic compass. It always points to Earth's magnetic north pole.

Explain what this tells you about the core of the Earth.

.....
..... [1]

5 An ultrasound scanner makes images of unborn babies using sound waves with a frequency of 3.5 MHz.

(a) Define frequency.

..... [1]

(b) A probe sends a beam of ultrasound into the body.

Part of the beam is reflected at each boundary between different tissues.

These reflections are detected when they arrive back at the probe.

This is an ultrasound image of an unborn baby. The size of its head, between points **A** and **B**, is measured by the ultrasound scanner.

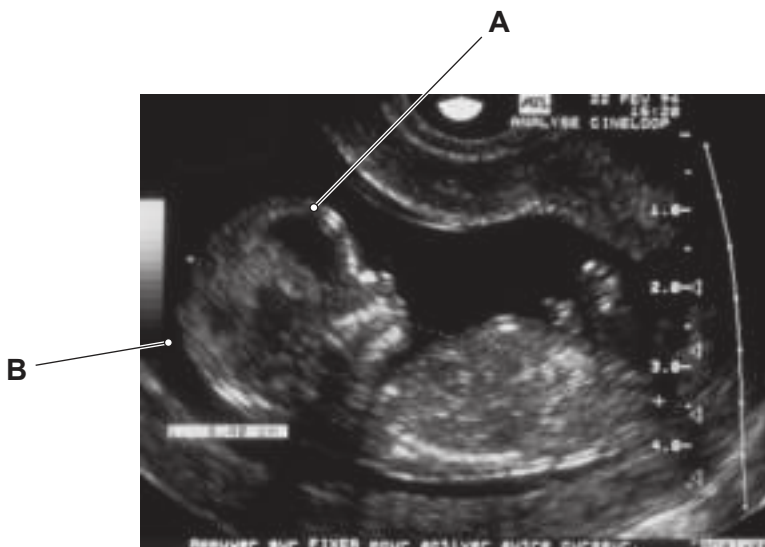

(i) The ultrasound waves travel at a speed of 1540 m/s through the head.

Calculate the wavelength of the waves.

Use the equation: wave speed = frequency \times wavelength

Give your answer in **standard form**.

Wavelength = m [4]

Part of the beam is reflected at **A** and part of the beam is reflected at **B**.

The trace on the screen shows the original pulse and the two reflected pulses arriving back at the probe.

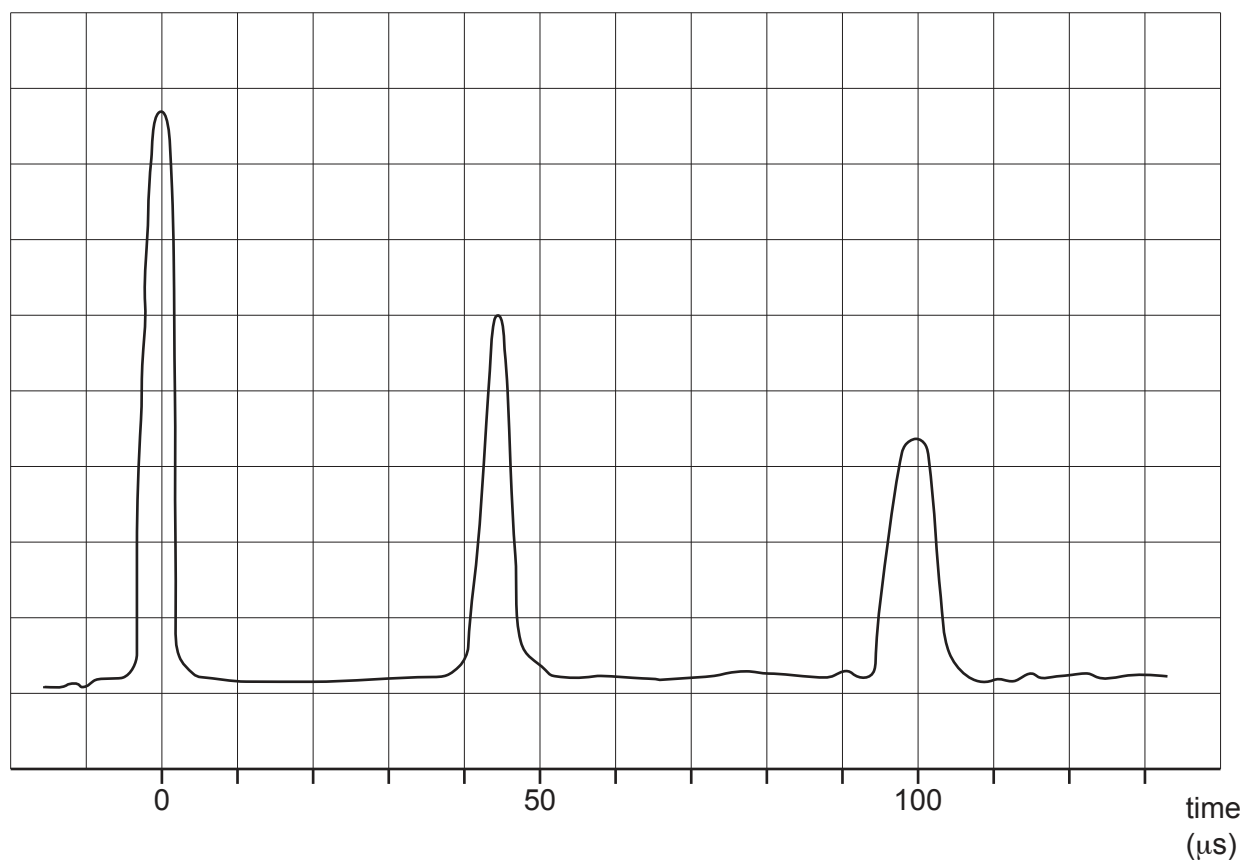

(ii) Use the trace to determine the **time delay** between the two reflections arriving back at the probe.

Time delay = μs [2]

(iii) Calculate the size of the baby's head.

Size of baby's head = m [5]

- 6 The diagram below shows how an aluminium sheet is compressed to make aluminium foil of the required thickness.

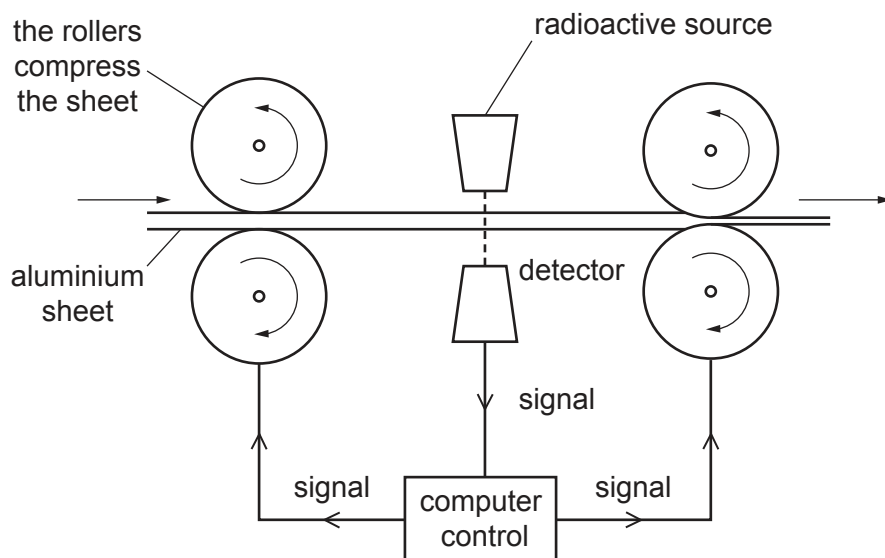

A detector measures how much radiation passes through the aluminium foil. A computer uses this measurement to calculate the thickness of the foil.

- (a) **Americium-241** and **promethium-147** are radioactive isotopes used in industrial processes.

Complete the decay equations for these isotopes.



(b) Which of these two isotopes, **americium-241** or **promethium-147** is most suitable for measuring the thickness of the aluminium foil?

Isotope =

Explain your answer.

.....
.....
.....
.....
.....
.....
..... [3]

(c) The radioactive source has a safety-shutter at the front which is closed when it is not in use.

Explain why the safety-shutter is needed.

.....
.....
.....
..... [2]

7 A London Underground train travels on a level track inside a tunnel.

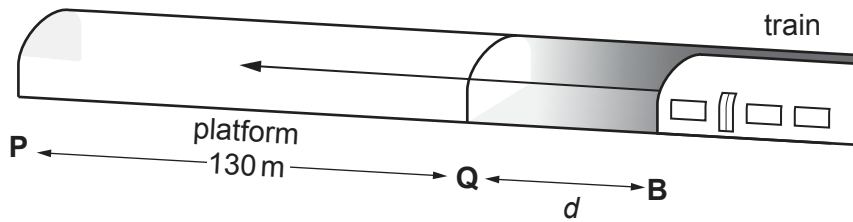

(a) The brakes are applied at point **B**. The train stops at point **P**.

The braking force is $2.3 \times 10^5 \text{ N}$ and the work done by the braking force is $4.6 \times 10^7 \text{ J}$.

(i) Calculate the distance, d .

Distance, $d = \dots\dots\dots \text{ m}$ [4]

(ii) Describe the main energy transfers that take place when the train slows to a stop.

.....

 [2]

- (b) The total mass of the train and passengers is 280 000 kg.

Calculate the force required to accelerate the train from rest to a speed of 12 m/s over a distance of 56 m.

Use the equation: kinetic energy = $\frac{1}{2} \times \text{mass} \times \text{speed}^2$

Force = N [5]

- (c) When the underground train system was built, the temperature of the air in the tunnels was about 14 °C.

Today it is about 23 °C and cooling systems are required.

Suggest why the temperature of the air in the tunnels has increased.

.....
.....
.....
..... [2]

- 8 Jamal is choosing a lamp that emits coloured light.

He looks at a lamp which has a white light at the centre and glass prisms surrounding it. Each prism produces a spectrum.

Jamal knows this is because the light is **refracted** when it moves from air to glass and from glass to air.

- (a) Explain what happens to the light that causes it to be refracted when it enters and leaves a glass prism.

.....

.....

..... [2]

- (b) The spectrum is from violet to red.

Which two statements are correct?

Tick **two** boxes.

Red light has the greatest energy.

Red light has the lowest frequency.

Red light is refracted most moving from glass to air.

Violet light has the longest wavelength.

Violet light is refracted most moving from air to glass.

[2]

- 9 A cheetah is the fastest land mammal. Cheetahs hunt gazelles.

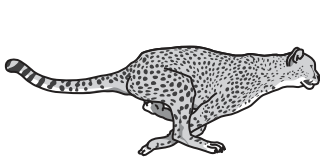

Cheetah



Gazelle

A cheetah has a maximum speed of 110 km/h.

- (a) Determine the cheetah's maximum speed in **metres per second**.

Give your answer to **2** significant figures.

Maximum speed = m/s [3]

- (b) (i) Explain the difference between a vector and a scalar quantity.

.....
 [1]

- (ii) Which of the quantities below are **vectors** and which are **scalars**?

Tick **one** box in each row.

Quantity	Vector	Scalar
Acceleration		
Displacement		
Distance		
Speed		
Velocity		

[1]

(c) Fig. 9.1 shows a speed-time graph of a gazelle which starts moving.

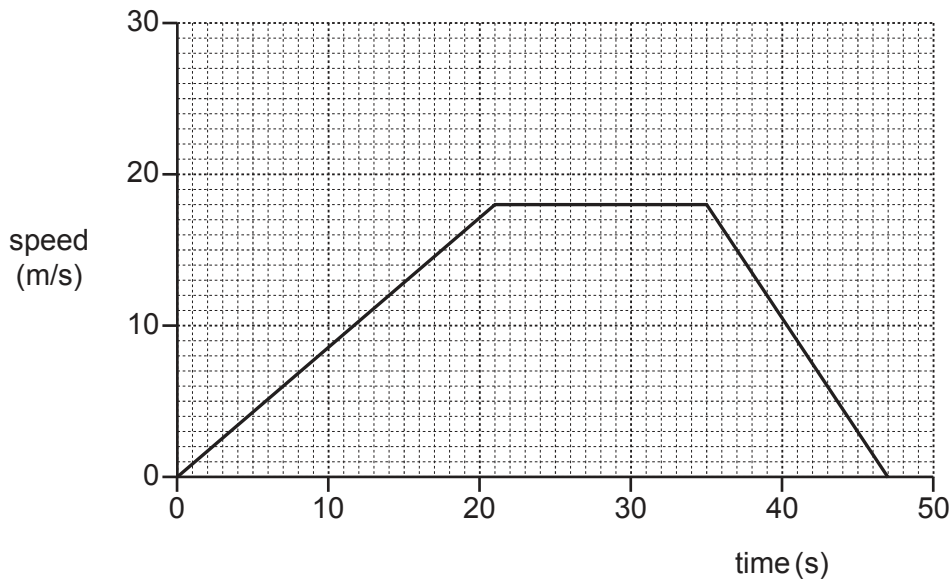

Fig. 9.1

(i) Use Fig. 9.1 to calculate the deceleration of the gazelle.

Deceleration = m/s^2 [3]

(ii) Use Fig. 9.1 to calculate the distance the gazelle travels as it decelerates.

Distance = m [3]

(d) A second gazelle starts moving at the same time. The table below describes its motion.

Stage	Motion of second gazelle
1	Constant acceleration from 0 m/s up to a speed of 26 m/s
2	Constant deceleration of 0.3 m/s^2 for 20 s
3	Deceleration at a constant rate to a stop.
4	The total time for the motion was 45 s

(i) Plot a graph on **Fig. 9.1** for the motion of the second gazelle.

[3]

(ii) **Without** further calculation, judge which gazelle travelled furthest.

Explain your answer.

.....
 [1]

10 The diagram shows a copper rod in a magnetic field.

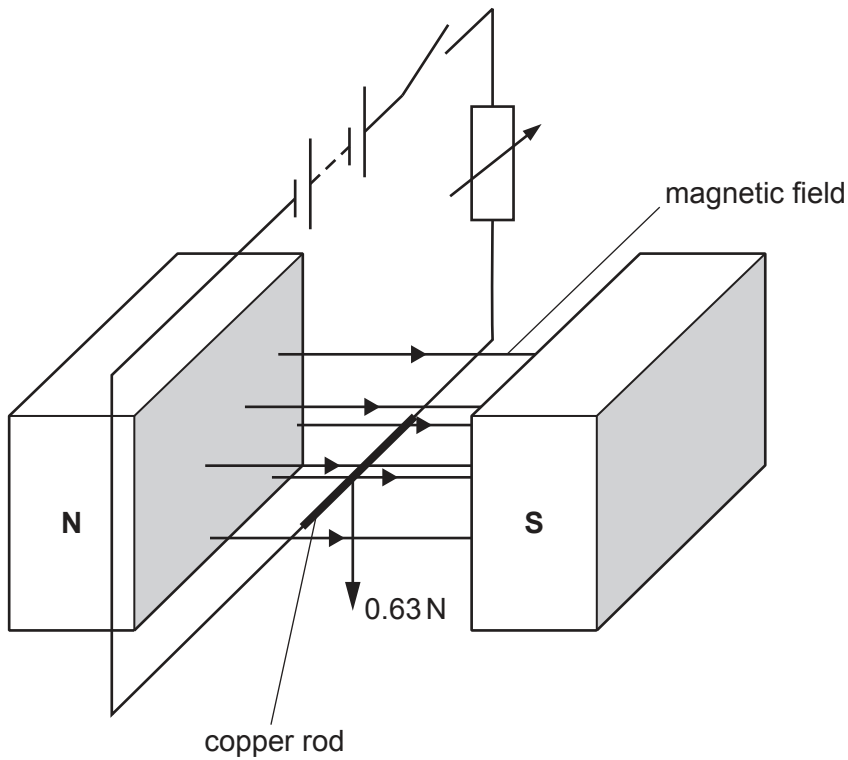

The copper rod is 0.25m long and weighs 0.63N. The entire length of the copper rod is on a horizontal table in a magnetic field of flux density 1.8T.

The magnetic field is at right angles to the table and the copper rod.

The copper rod is connected to an electric circuit which is switched on, and the current is slowly increased.

Calculate the **current** needed to cause a force on the copper rod equal to its weight.

Current = A [2]

11 Buildings need heating and cooling systems.

- (a) Describe the changes that take place when a liquid is heated, and then changes state from liquid to gas.

Use ideas from the particle model in your answer.

.....

.....

.....

.....

.....

..... [3]

In a sustainable office building, water is circulated to keep the building cool in the day.

This water is cooled by passing through a tank containing stainless steel spheres. Inside the spheres there is a material called a phase change material (PCM) that melts when the water is warm.

When the water is cooled by the night air it freezes the PCM again.

- (b) Describe how the energy transfers involved help to cool the building at night.

.....

.....

.....

.....

.....

..... [3]

- (c) These graphs show the temperature change in a 100 g mass of PCM **A** and a 100 g mass of PCM **B** when they are each heated by a 120 W heater at the same constant rate.

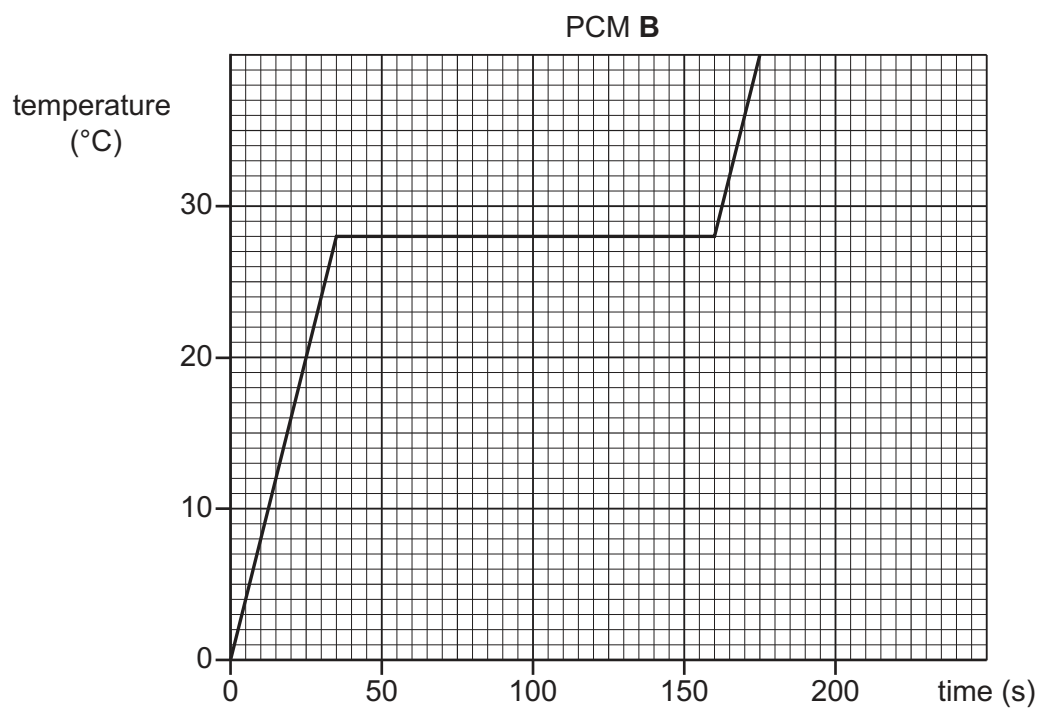
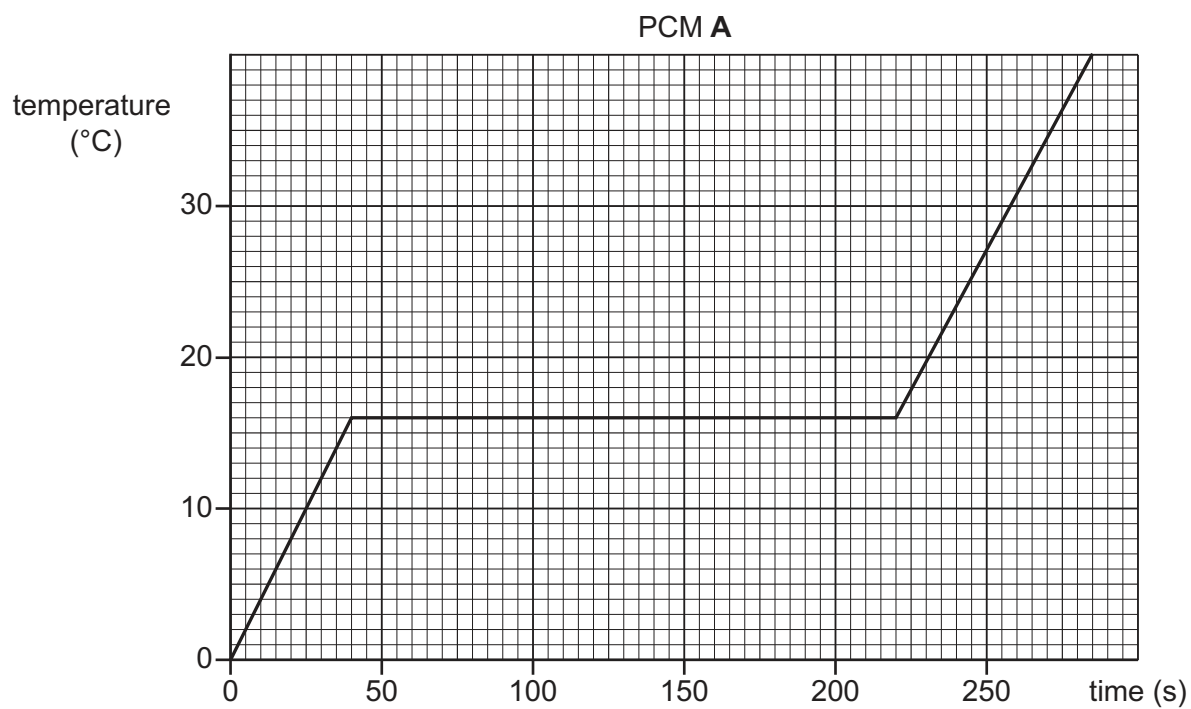

(i) The ideal building temperature is 22 °C.

Which PCM, **A** or **B**, is more suitable for cooling the building? Justify your answer.

.....
.....
.....
..... [2]

(ii) Calculate the specific latent heat of PCM **B**.

Specific latent heat = J/kg [5]

END OF QUESTION PAPER

ADDITIONAL ANSWER SPACE

If additional space is required, you should use the following lined page(s). The question number(s) must be clearly shown in the margin(s).

A large rectangular area with a vertical solid line on the left side and horizontal dotted lines across the rest of the page, providing space for writing answers.



Oxford Cambridge and RSA

Copyright Information

OCR is committed to seeking permission to reproduce all third-party content that it uses in its assessment materials. OCR has attempted to identify and contact all copyright holders whose work is used in this paper. To avoid the issue of disclosure of answer-related information to candidates, all copyright acknowledgements are reproduced in the OCR Copyright Acknowledgements Booklet. This is produced for each series of examinations and is freely available to download from our public website (www.ocr.org.uk) after the live examination series.

If OCR has unwittingly failed to correctly acknowledge or clear any third-party content in this assessment material, OCR will be happy to correct its mistake at the earliest possible opportunity.

For queries or further information please contact The OCR Copyright Team, The Triangle Building, Shaftesbury Road, Cambridge CB2 8EA.

OCR is part of the Cambridge Assessment Group; Cambridge Assessment is the brand name of University of Cambridge Local Examinations Syndicate (UCLES), which is itself a department of the University of Cambridge.